

REV	CHANGE DESCRIPTION	ECN	DATE	REVISED BY	APPROVED BY

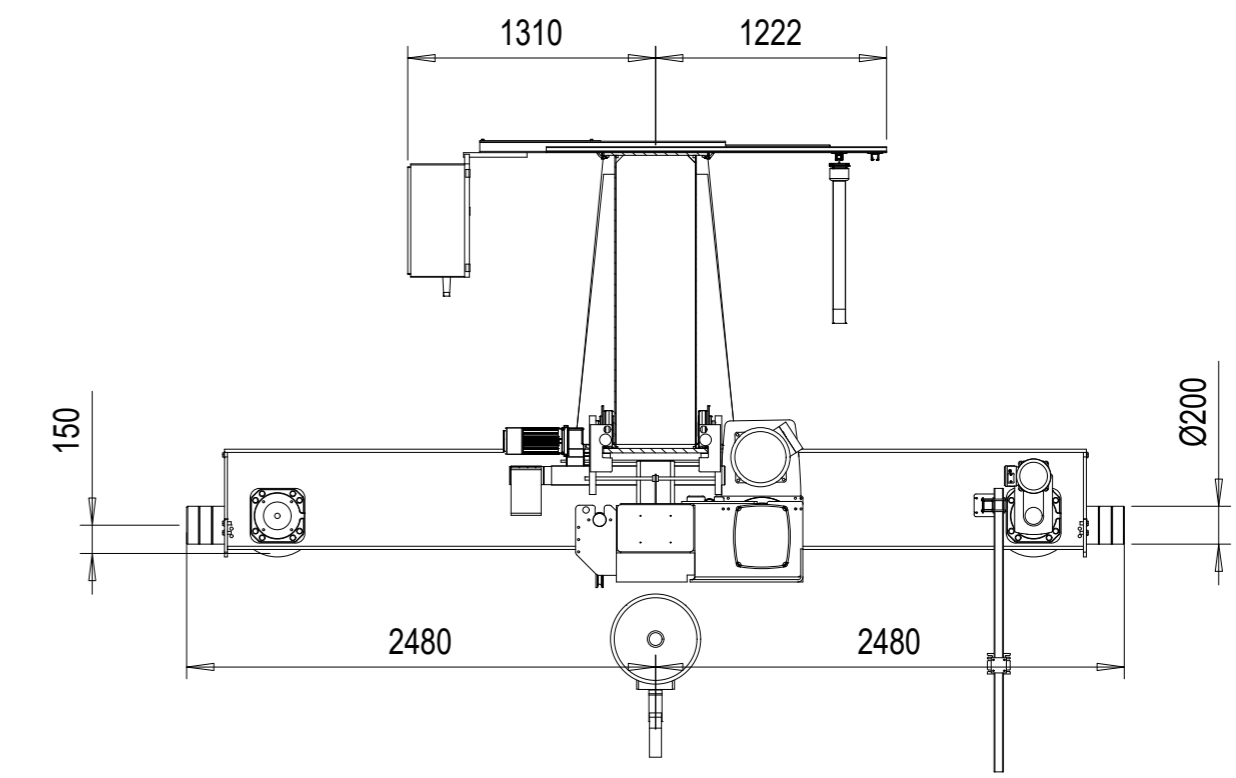

VIEW A-A

**TECHNICAL DATA**

CRANE	
LOAD	: 25000 kg
SPAN	: 28.5 m
LIFTING HEIGHT	: 12 m
TRAVELLING SPEED	: 40/10 m/min 2-speed pole change
WEIGHT OF BRIDGE	: 13510 kg
TOTAL WEIGHT	: 16700 kg
CRANE CLASSIFICATION	: U4/Q2, EN13001-1
CRANE DRIVE GROUP	: 25 m (D_lin6) / M5
LENGTH OF RUNWAY	: 50 m
HOIST	
HOISTING SPEED	: 3.1/0.52 m/min 2-speed
TRAVERSING SPEED	: 20/5 m/min 2-speed pole change
WEIGHT OF TROLLEY	: 3190 kg
HOIST GROUP	: 3,0 + 3,0 m (D_lin4) / ISO M4
ELECTRICAL EQUIPMENT	
MAIN/CONTROL VOLTAGE	: 380 / 48 V; 50 Hz
SUPPLY POWER	: 18.6 kW

**TOLERANCES**

CRANE	:
RUNWAY	:

**USE OF CRANE**

: Indoor Use crane -10° ... 40° C  
 CUSTOMER ORGANIZES SAFE  
 PLATFORM FOR CRANE SERVICE

Project sketch - for information only  
 Subject to changes without prior notice  
 Projektskizze - Änderungen vorbehalten

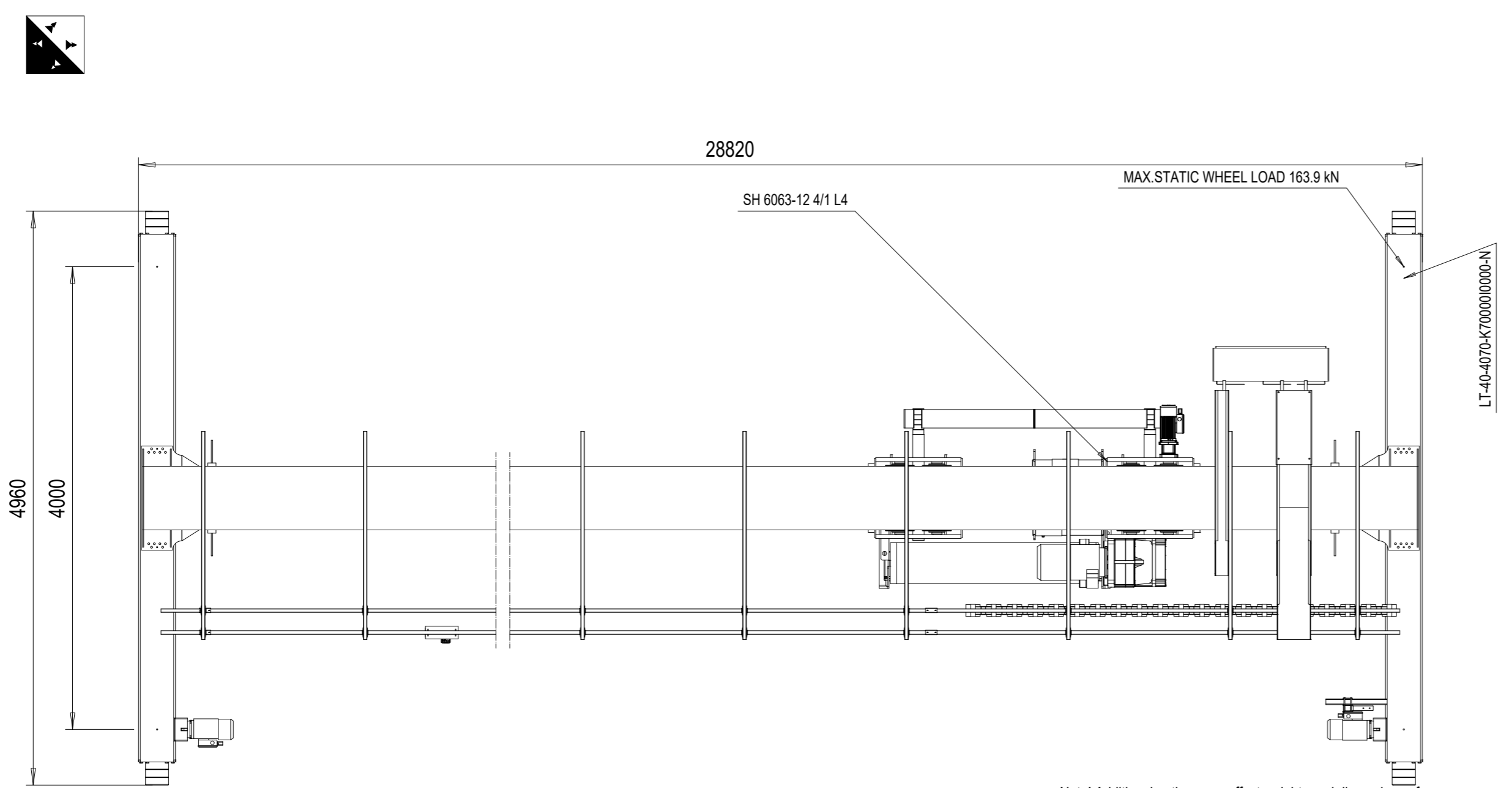

Note! Additional options can affect weights and dimensions of some components.

Approved:	Place	Date	Company (Company stamp)
Customer			
	Free size tolerance	Quotation No.	Version DAS
	Material	Order No.	NSL
	Reproduction and transmission to third parties is not permitted We reserve all rights under copyright for this drawing <b>SHS25t x 28.5m Hol:12m</b>		TCHAR
Company: STEPHAN CraneSystems GmbH		Datum	Scale
Drawn by 29.11.2018 DMA/XRS		Name	1:40
Checked by		<b>25-28.5-12-O</b>	
Issue		Copy to	
N/a		Replaced by	

This document is the absolute property of STEPHAN CraneSystems GmbH. This document must not be copied without the written permission of STEPHAN CraneSystems GmbH or its parent company STAHL CraneSystems GmbH. The contents thereof must not be disclosed to a third party nor be used for any unauthorized purpose. Contravention will be prosecuted.

REV	CHANGE DESCRIPTION	ECN	DATE	REVISED BY	APPROVED BY
-----	--------------------	-----	------	------------	-------------

25-28.5-12-O-I

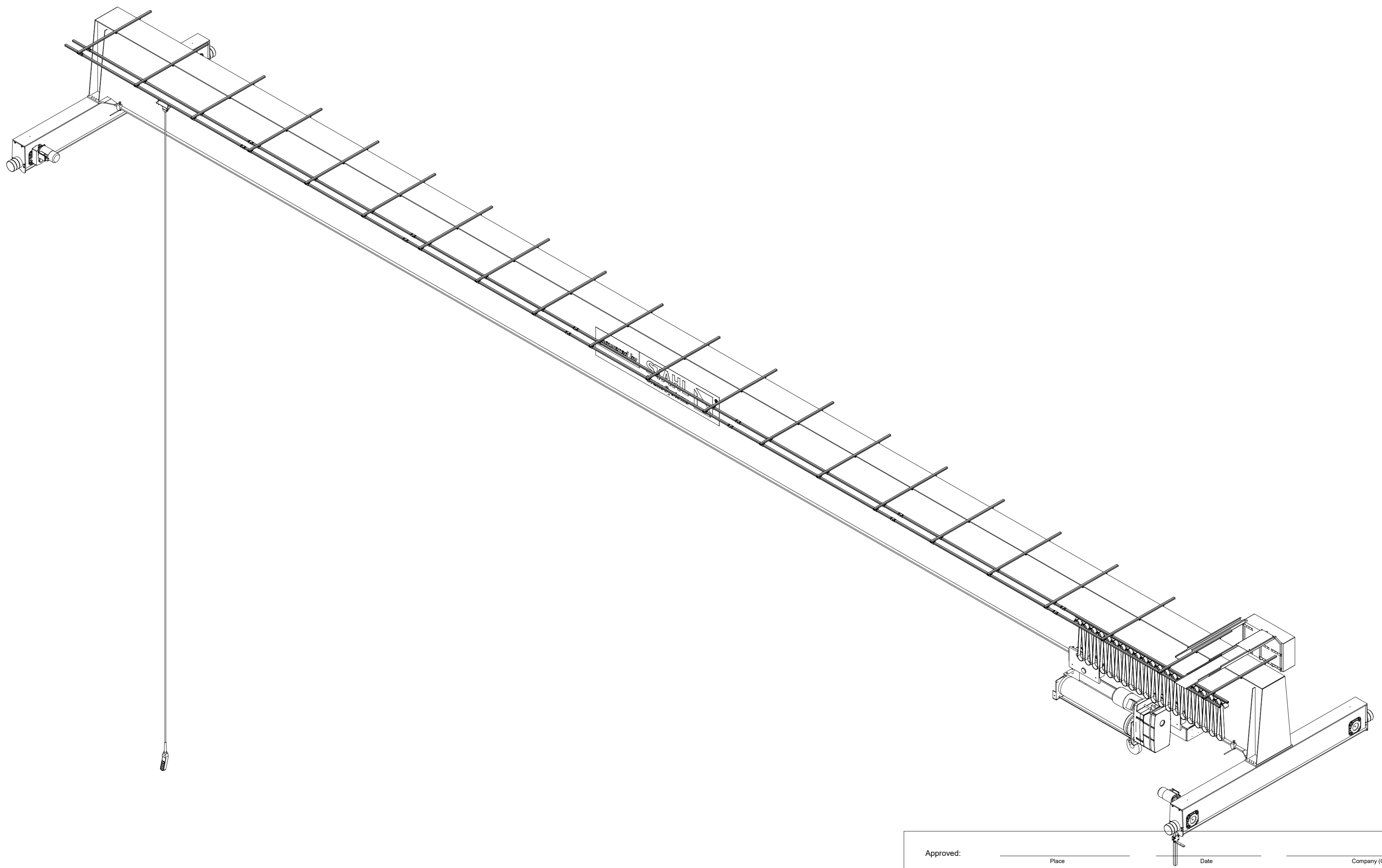

This document is the absolute property of STEPHAN CraneSystems GmbH. This document must not be copied without the written permission of STEPHAN CraneSystems GmbH or its parent company STAHL CraneSystems GmbH. The contents thereof must not be disclosed to a third party nor be used for any unauthorized purpose. Contravention will be prosecuted.

Approved: _____		Place _____		Date _____		Company (Company stamp) _____	
Customer _____		Free size tolerance _____		Quotation No. _____		Version DAS	
		Material _____		Order No. _____		NSL	
				Reproduction and transmission to third parties is not permitted		TCHAR	
				We reserve all rights under copyright for this drawing		Scale	
				SHS25t x 28.5m Hol:12m		1:40	
Company: STEPHAN CraneSystems GmbH		Datum _____ Name _____		25-28.5-12-O-I		Copy to _____	
Issue _____ N/a _____		Drawn by 29.11.2018 DMA/XRS		Replaced by _____			
		Checked by _____					
		Released _____					