

12.5-16.5-12-O

REV	CHANGE DESCRIPTION	ECN	DATE	REVISED BY	APPROVED BY
-----	--------------------	-----	------	------------	-------------

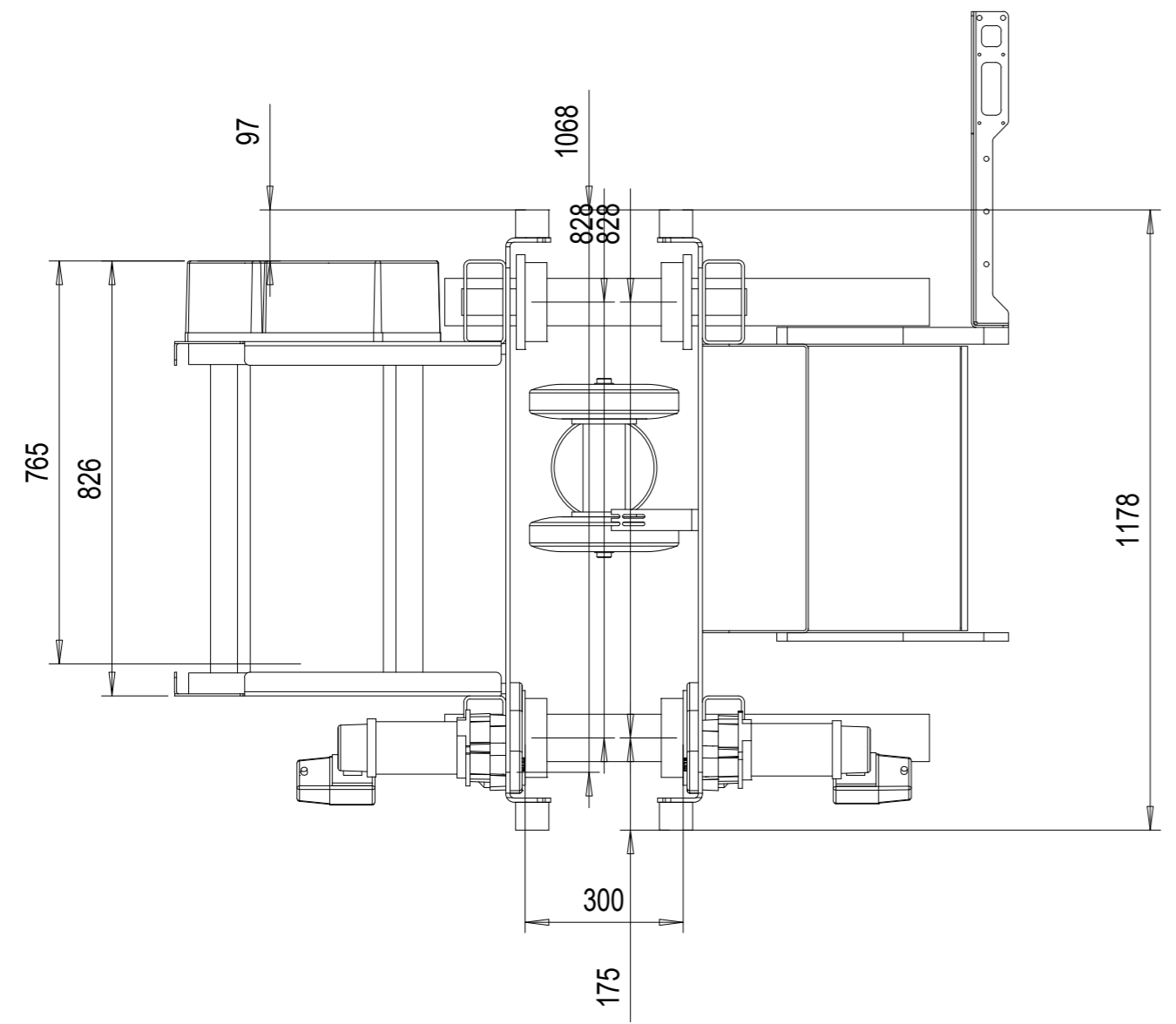
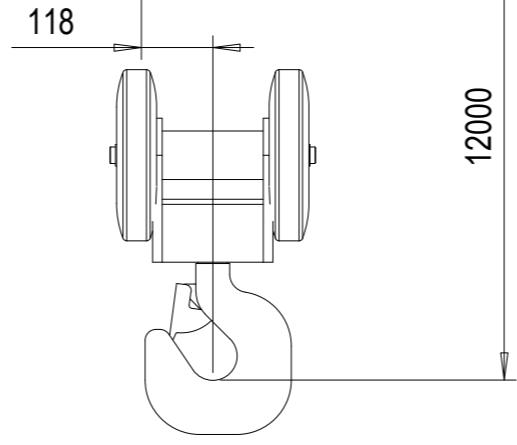
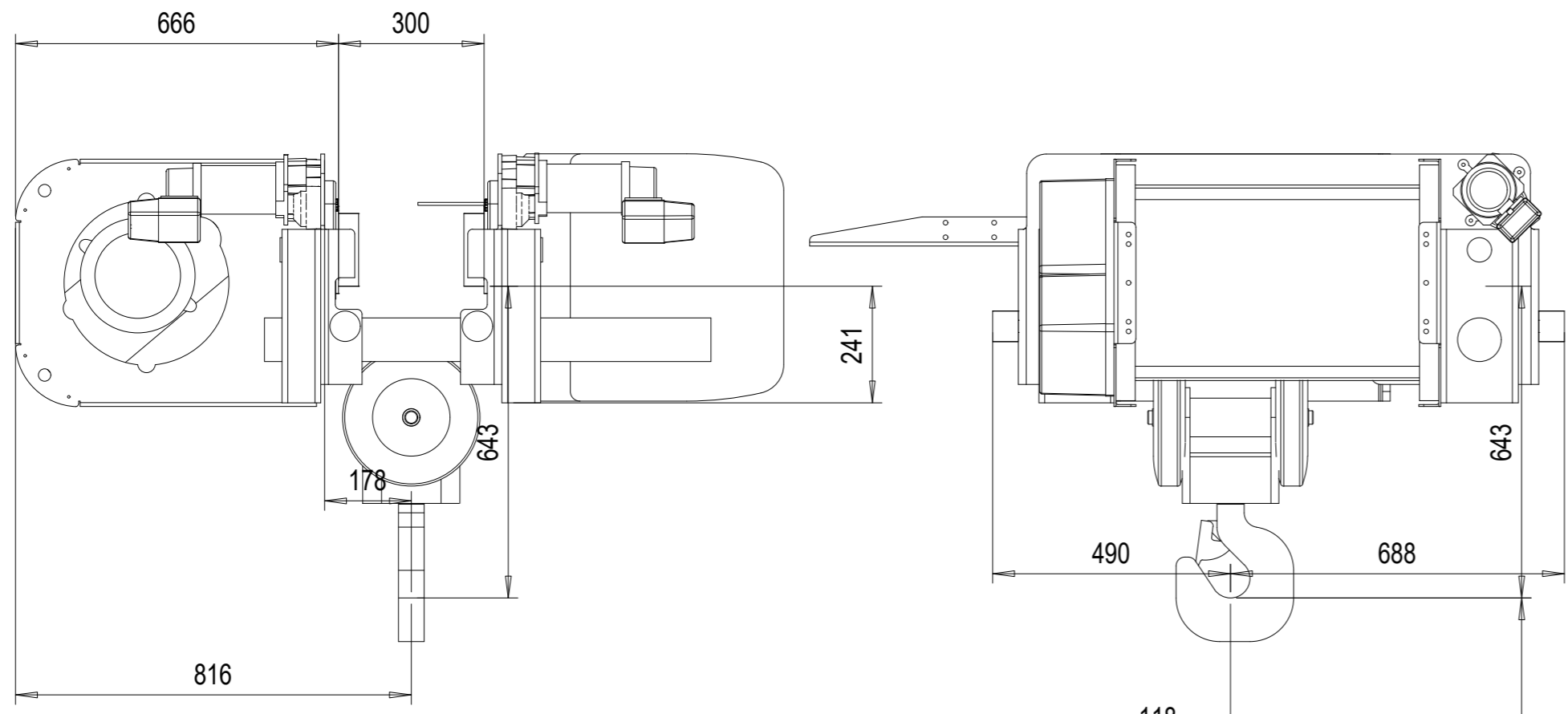

TECHNICAL DATA

LOAD	: 12500 kg
LIFTING HEIGHT	: 12 m
HOISTING SPEED	: 4/0,67 m/min 2-speed
TRAVERSING SPEED	: 24/6 m/min 2-speed pole change
WEIGHT OF HOIST	: 760 kg
HOIST GROUP	: ISO M4
MAIN / CONTROL VOLTAGE	: 380 / 48 V; 50 Hz

Pos	Amount	Description	Specification
		DMA/SCG	
		Design	Chd
		28.03.2019	Appd
		Date	Ref drawing
		Schwäbisch Hall	DAS / 2.98.18
		Dept	Vx proj
		SWF KRANTECHNIK	BD04L4EEP5
			1:12.5
			M-film
			Issue

SWF Krantechnik reserves the right to alter or amend the above information without notice. The document and the information contained herein is the exclusive property of SWF Krantechnik and represents a non-public, confidential and proprietary trade secret that may not be reproduced, disclosed to third parties, altered or otherwise employed in any manner whatsoever without the express written consent of SWF Krantechnik GmbH. Copyright © SWF Krantechnik. All rights reserved.

12.5-16.5-12-O

REV	CHANGE DESCRIPTION	ECN	DATE	REVISED BY	APPROVED BY

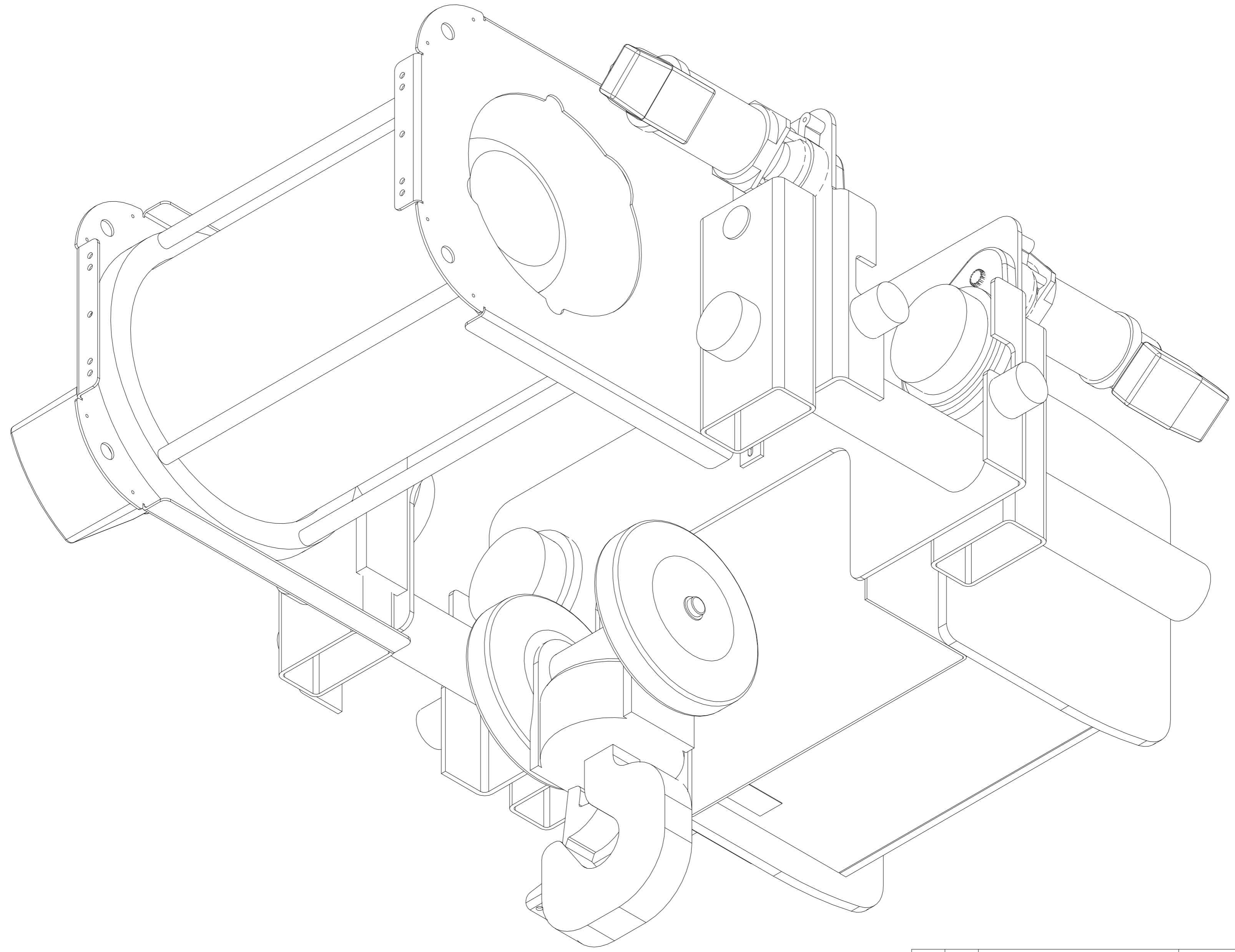

SWF Krantechnik reserves the right to alter or amend the above information without notice.
 This document and the information contained herein, is the exclusive property of SWF Krantechnik and represents a non-patented
 commercial product. Any unauthorized copying or distribution of this document, in any form or by any means, is strictly prohibited.
 All rights reserved.

Pos	Amount	Description	Specification		
		DMA/SCG			DAS / 2.98.18
		Design	Chd	Appd	Ref drawing
		28.03.2019	BD04L4EEP5		Vx proj
		Date			
		Schwäbisch Hall			
		Dept			
		SWF KRANTECHNIK			

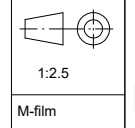

1:2.5

M-film

Issue