

20-22.5-10-0

REV	CHANGE DESCRIPTION	ECN	DATE	REVISED BY	APPROVED BY
-----	--------------------	-----	------	------------	-------------

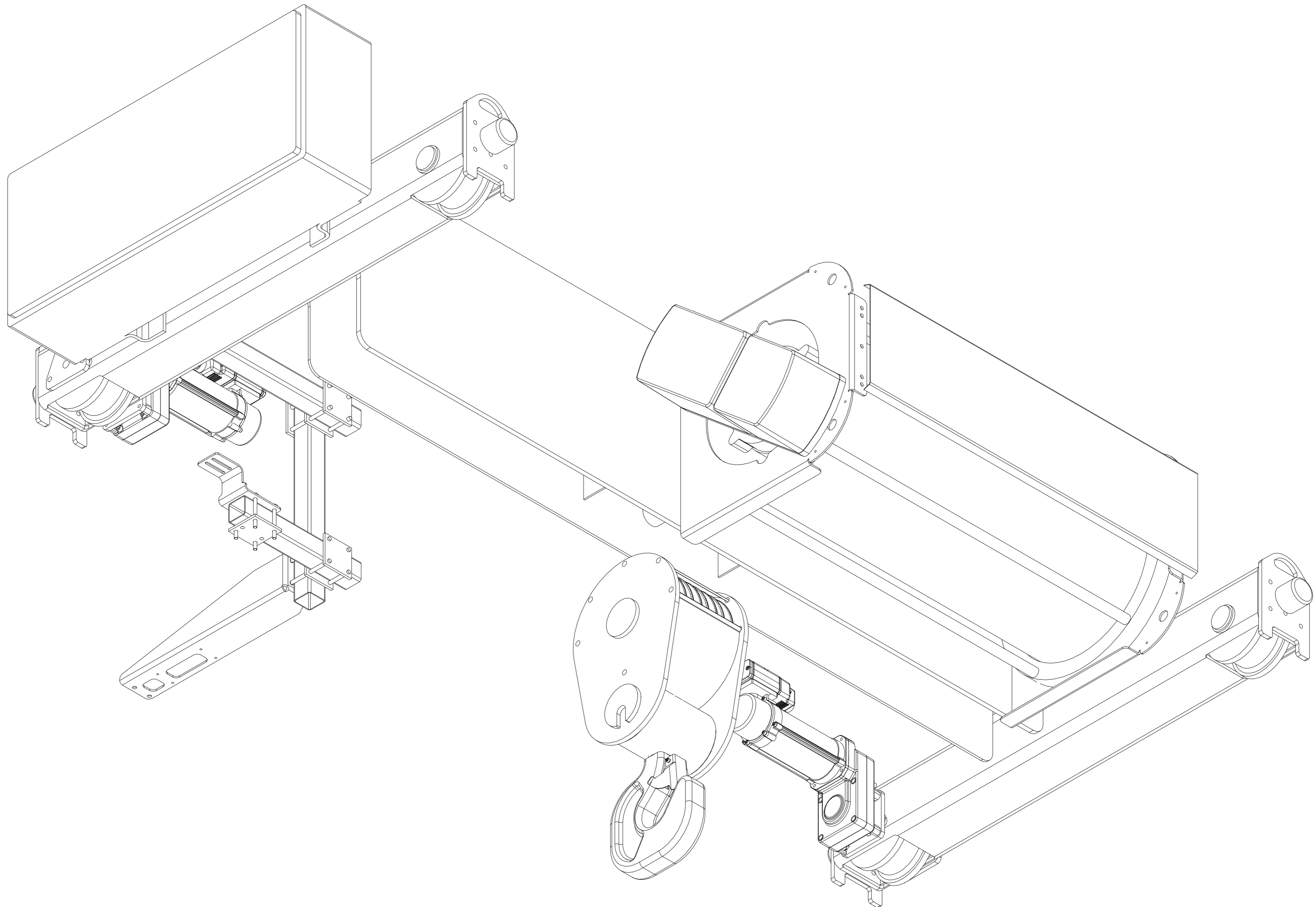

SWF Kramtechnik reserves the right to alter or amend the above information without notice.
 This document and the information contained herein, is the exclusive property of SWF Kramtechnik and represents a non-patented
 commercial and industrial process. Any disclosure or use of the information contained herein, in any form or by any means,
 without the express written consent of SWF Kramtechnik GmbH, Copyright © SWF Kramtechnik. All rights reserved.

Pos	Amount	Description	Specification		
		DMA/SCG			DAS / 2.98.18
		Design	Chd	Appd	Ref drawing
		03.04.2019	BD08M4GFP5		
		Date			
		Schwäbisch Hall			
		Dept			
		SWF KRANTECHNIK			
			1:2.5		
			M-film		
			Issue		