

5-10.5-12-ex-OEx

| REV | CHANGE DESCRIPTION | ECN | DATE | REVISED BY | APPROVED BY |
|-----|--------------------|-----|------|------------|-------------|
|-----|--------------------|-----|------|------------|-------------|

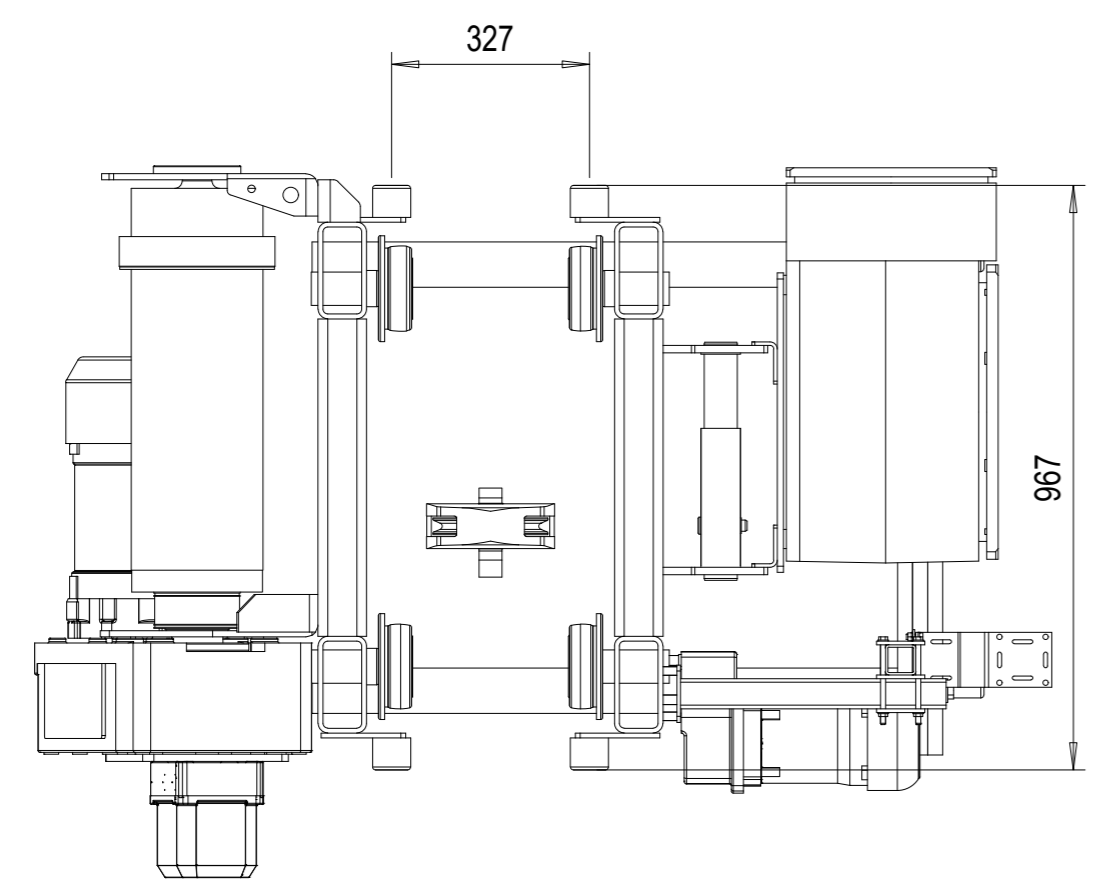
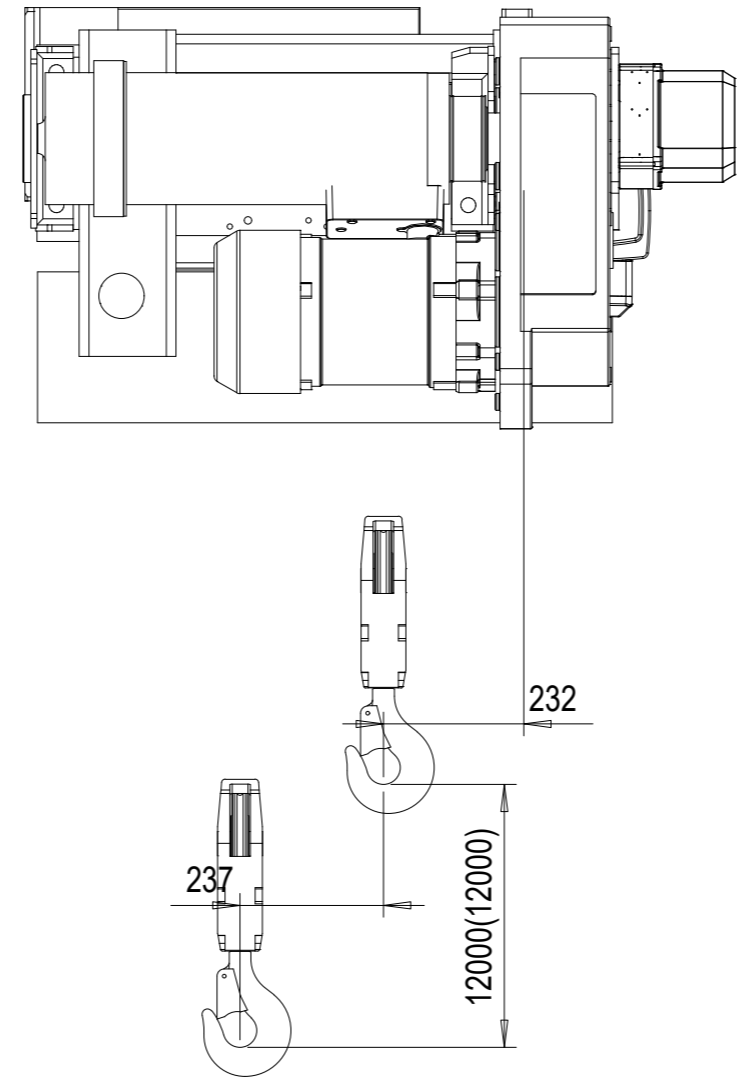
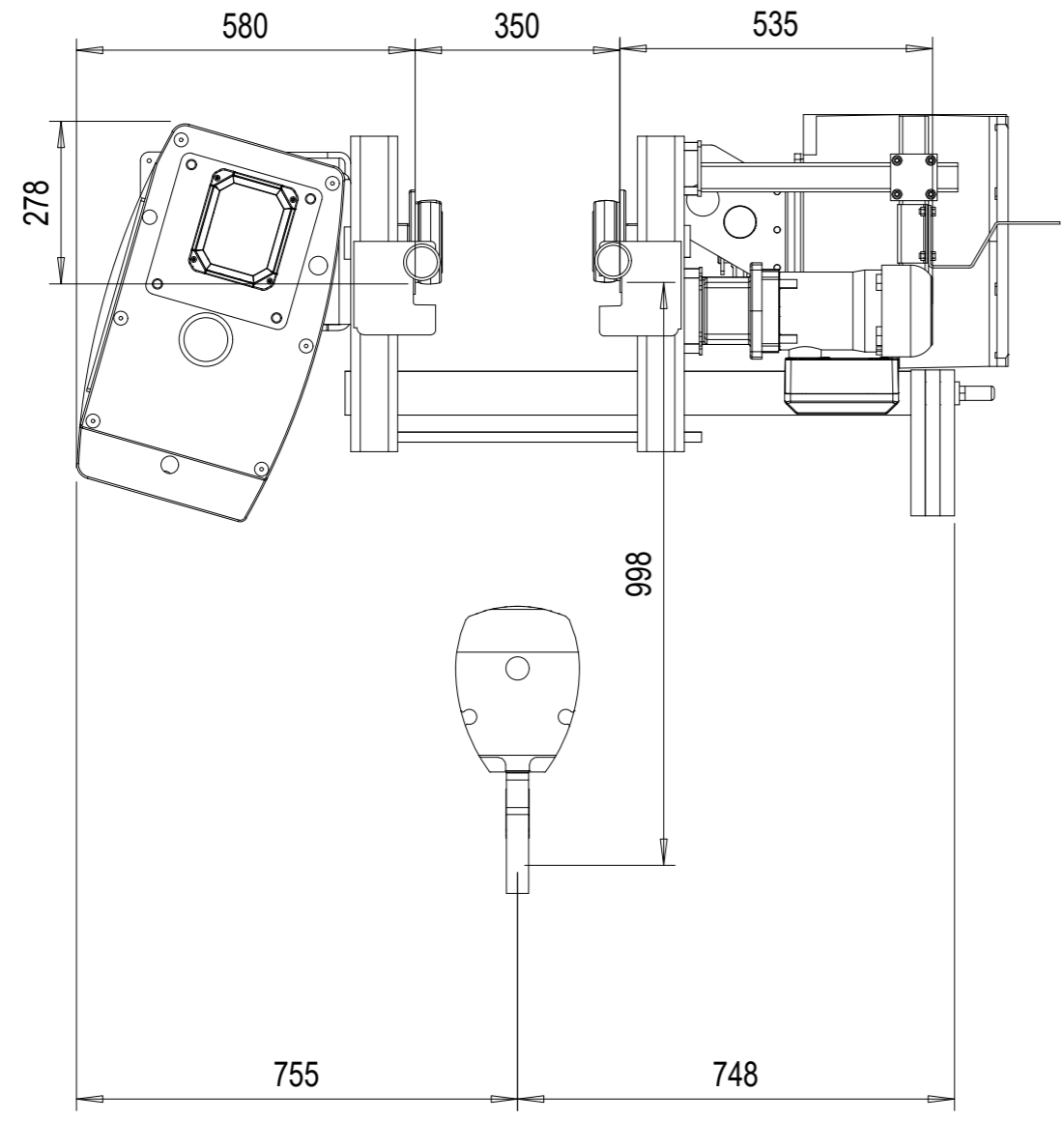

Marking : Ex II 2G Ex de IIB T4 Gb/Ex II 2G ck IIB T4
 Ambient temperature : -10°...40° C

| TECHNICAL DATA | |
|------------------------|----------------------------------|
| LOAD | : 5000 kg |
| LIFTING HEIGHT | : 12 m |
| HOISTING SPEED | : 5/0,83 m/min 2-speed |
| TRAVERSING SPEED | : 20/5 m/min 2-speed pole change |
| WEIGHT OF HOIST | : 750 kg |
| HOIST GROUP | : 4,0 + 4,0 m (D_lin4) / ISO M5 |
| MAIN / CONTROL VOLTAGE | : 380 / 48 V; 50 Hz |

Approved: _____ Place _____ Date _____ Company (Company stamp) _____
 Customer _____

| | | | |
|---|---|--|------------------------|
| | Free size tolerance | Quotation No. | Version DAS |
| | Material | Order No. | NSL |
| | Reproduction and transmission to third parties is not permitted We reserve all rights under copyright for this drawing SHS EX 5t x 10.5m HoI:12m | | TCHAR |
| Company: STEPHAN CraneSystems GmbH | | Drawn by: 27.05.2019 DMA/XRS Checked by: _____ Released: _____ | Scale 1:12.5 |
| Issue: _____ N/a _____ | | Replaced by: _____ | Copy to: _____ |

Note! Additional options can affect weights and dimensions of some components.

This document is the absolute property of STEPHAN CraneSystems GmbH. This document must not be copied without the written permission of STEPHAN CraneSystems GmbH or its parent company STAHL CraneSystems GmbH. The contents thereof must not be disclosed to a third party nor be used for any unauthorized purpose. Contravention will be prosecuted.

5-10.5-12-ex-OEx

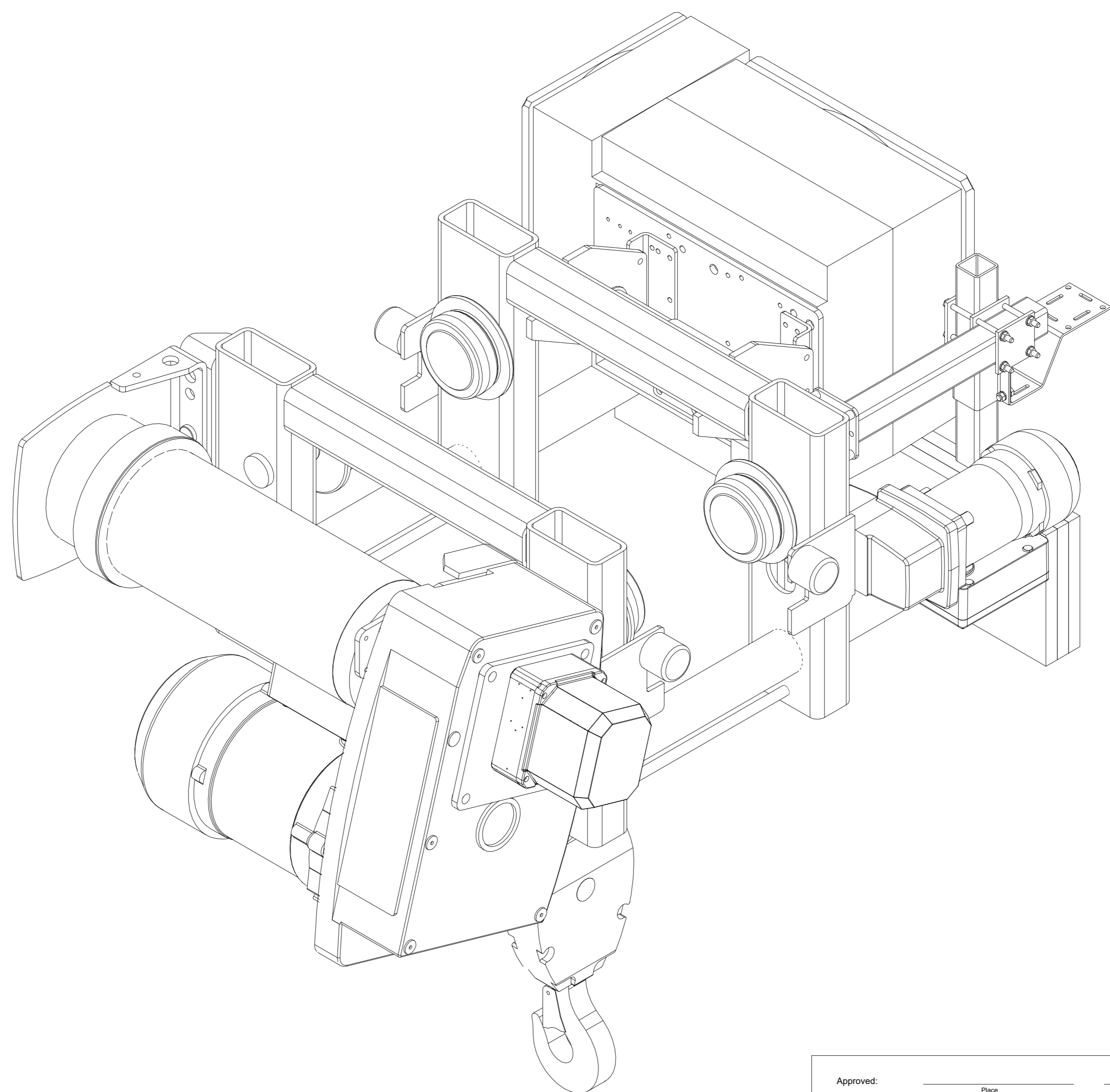

| REV | CHANGE DESCRIPTION | ECN | DATE | REVISED BY | APPROVED BY |
|-----|--------------------|-----|------|------------|-------------|
|-----|--------------------|-----|------|------------|-------------|

This document is the absolute property of STEPHAN CraneSystems GmbH. This document must not be copied without the written permission of STEPHAN CraneSystems GmbH or its parent company STAHL CraneSystems GmbH. This document is not to be used for any unauthorized purpose. Contravention will be prosecuted.

| | | | | | | | |
|---|--|---------------------------|--|---|--|-------------------------------|--|
| Approved: _____ | | Place _____ | | Date _____ | | Company (Company stamp) _____ | |
| Customer _____ | | Free size tolerance _____ | | Quotation No. _____ | | Version DAS | |
|  | | Material _____ | | Order No. _____ | | NSL | |
| | | | | Reproduction and transmission to third parties is not permitted We reserve all rights under copyright for this drawing | | TCHAR | |
| | | | | SHS EX 5t x 10.5m Hol:12m | | Scale | |
| | | | | 5-10.5-12-ex-OEx | | 1:2.5 | |
| Company: STEPHAN CraneSystems GmbH | | Datum _____ | | Name _____ | | Copy to _____ | |
| Issue _____ | | N/a | | Released _____ | | Replaced by _____ | |

Note! Additional options can affect weights and dimensions of some components.

1 2 3 4 5 6 7 8 9 10 11 12

A B C D E F G H

A B C D E F G H

1 2 3 4 5 6 7 8 9 10 11 12