

25-22.5-18-O

REV	CHANGE DESCRIPTION	ECN	DATE	REVISED BY	APPROVED BY
-----	--------------------	-----	------	------------	-------------

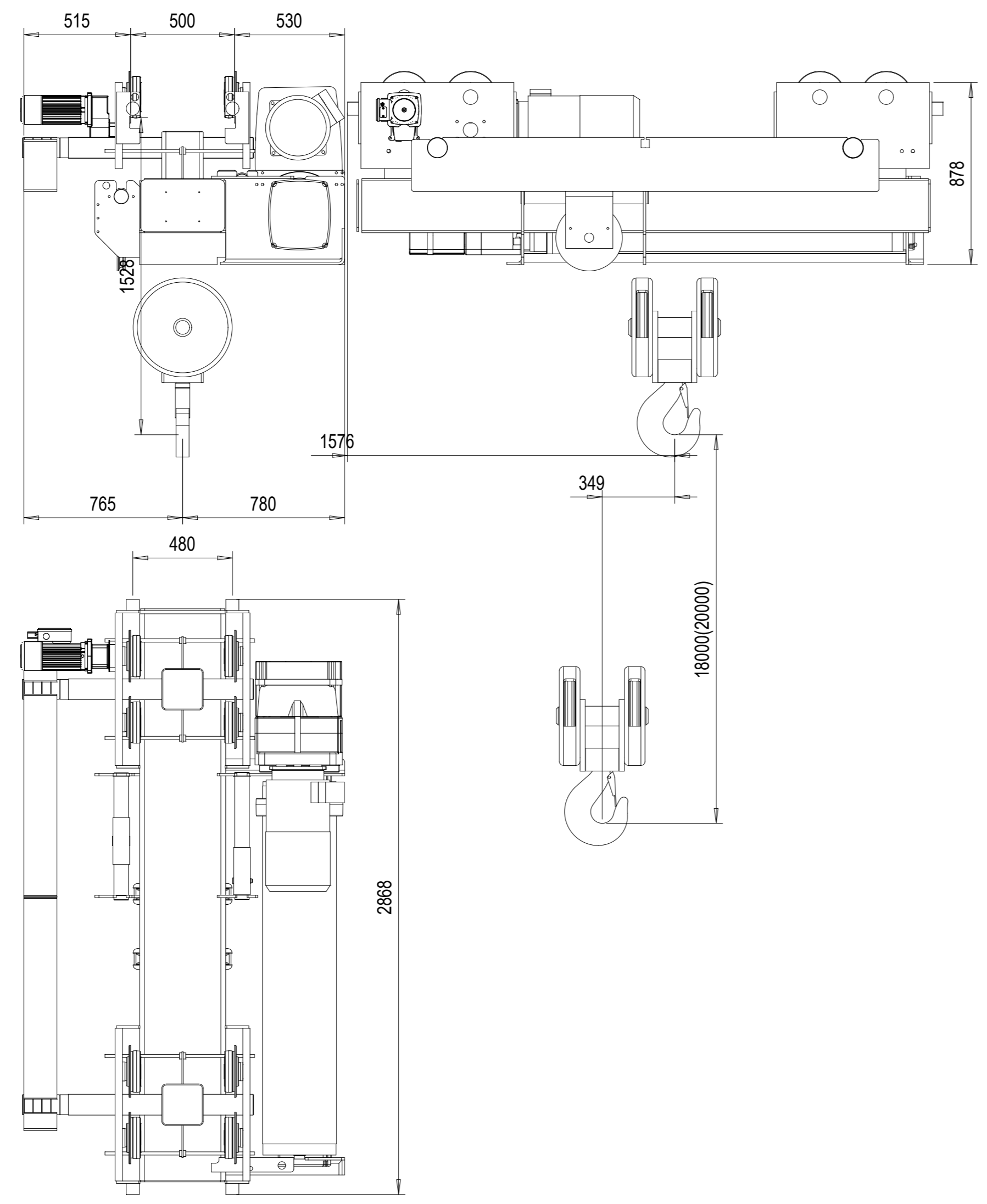

TECHNICAL DATA			
LOAD	: 25000 kg		
LIFTING HEIGHT	: 18 m		
HOISTING SPEED	: 3,1/0,52 m/min 2-speed		
TRAVERSING SPEED	: 20/5 m/min 2-speed pole change		
WEIGHT OF HOIST	: 3188 kg		
HOIST GROUP	: 4,0 + 4,0 m (D_lin4) / ISO M4		
MAIN / CONTROL VOLTAGE	: 380 / 48 V; 50 Hz		
Approved: _____ Place _____ Date _____ Company (Company stamp) _____			
Customer _____			
<b>STAHL</b> CraneSystems	Free size tolerance	Quotation No.	Version DAS
	Material	Order No.	NSL
	Reproduction and transmission to third parties is not permitted We reserve all rights under copyright for this drawing		TCHAR
SHS25t x 22.5m Hol:18m		Scale	1:20
Company: STEPHAN CraneSystems GmbH		Copy to	
Drawn by	Datum	Name	25-22.5-18-O
30.05.2019	DMA/XRS		
Checked by			
Issue	N/a	Released	Replaced by

Note! Additional options can affect weights and dimensions of some components.

This document is the absolute property of STEPHAN CraneSystems GmbH. This document must not be copied without the written permission of STEPHAN CraneSystems GmbH or its parent company STAHL CraneSystems GmbH. The contents thereof must not be disclosed to a third party nor be used for any unauthorized purpose. Contravention will be prosecuted.

25-22.5-18-O

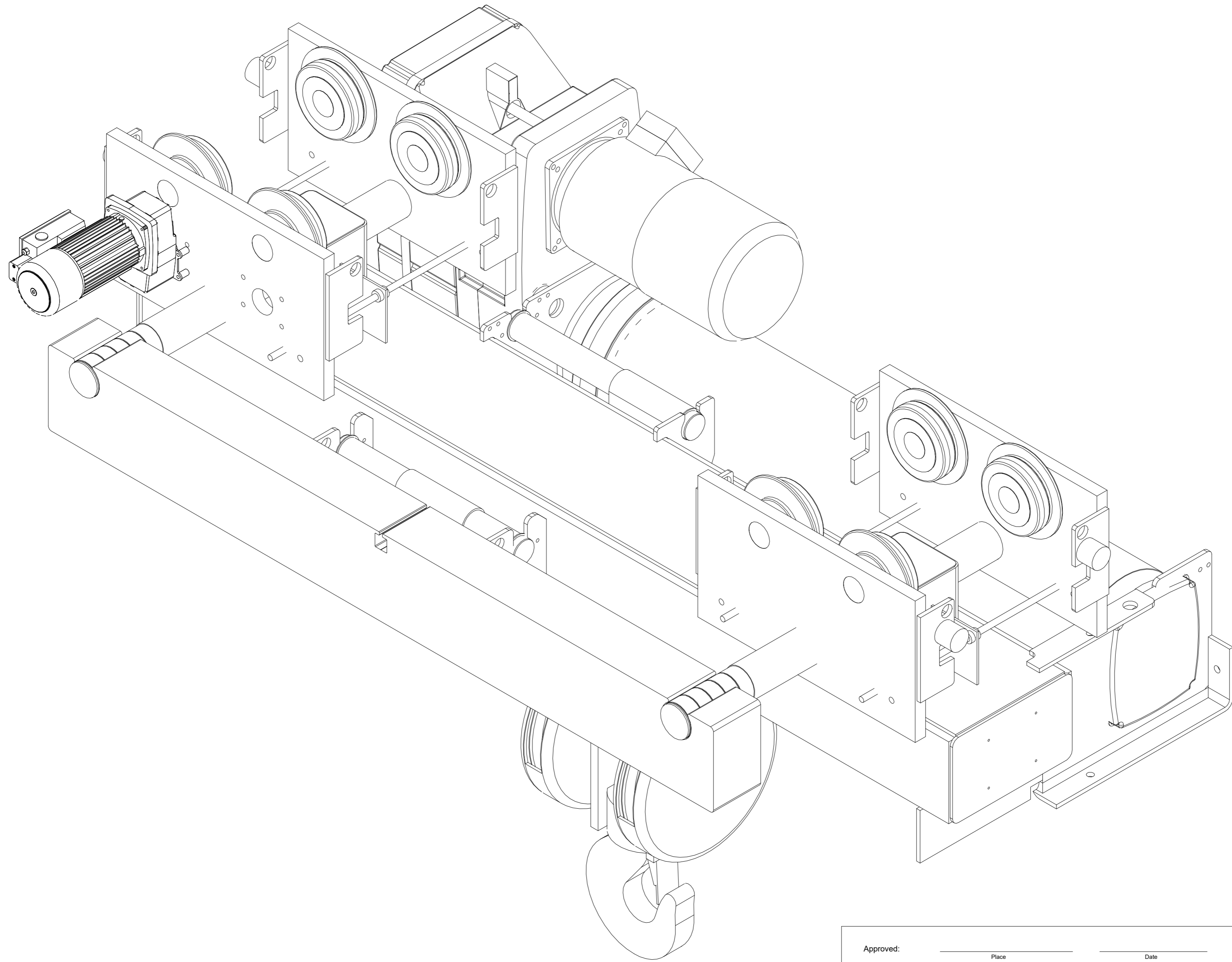

REV	CHANGE DESCRIPTION	ECN	DATE	REVISED BY	APPROVED BY
-----	--------------------	-----	------	------------	-------------

This document is the absolute property of STEPHAN CraneSystems GmbH. This document must not be copied without the written permission of STEPHAN CraneSystems GmbH or its parent company STAHL CraneSystems GmbH. This document is intended for internal use only and is not to be used for any unauthorized purpose. Contravention will be prosecuted.

Approved: _____		Place _____		Date _____		Company (Company stamp) _____	
Customer _____		Free size tolerance _____		Quotation No. _____		Version DAS	
		Material _____		Order No. _____		NSL	
				Reproduction and transmission to third parties is not permitted We reserve all rights under copyright for this drawing		TCHAR	
				SHS25t x 22.5m Hol:18m		Scale	
				25-22.5-18-O		1:2.5	
Company: STEPHAN CraneSystems GmbH		Datum _____		Name _____		Copy to _____	
Issue _____		N/a _____		Released _____		Replaced by _____	

Note! Additional options can affect weights and dimensions of some components.