

REV	CHANGE DESCRIPTION	ECN	DATE	REVISED BY	APPROVED BY
-----	--------------------	-----	------	------------	-------------

16-4.5-6-O

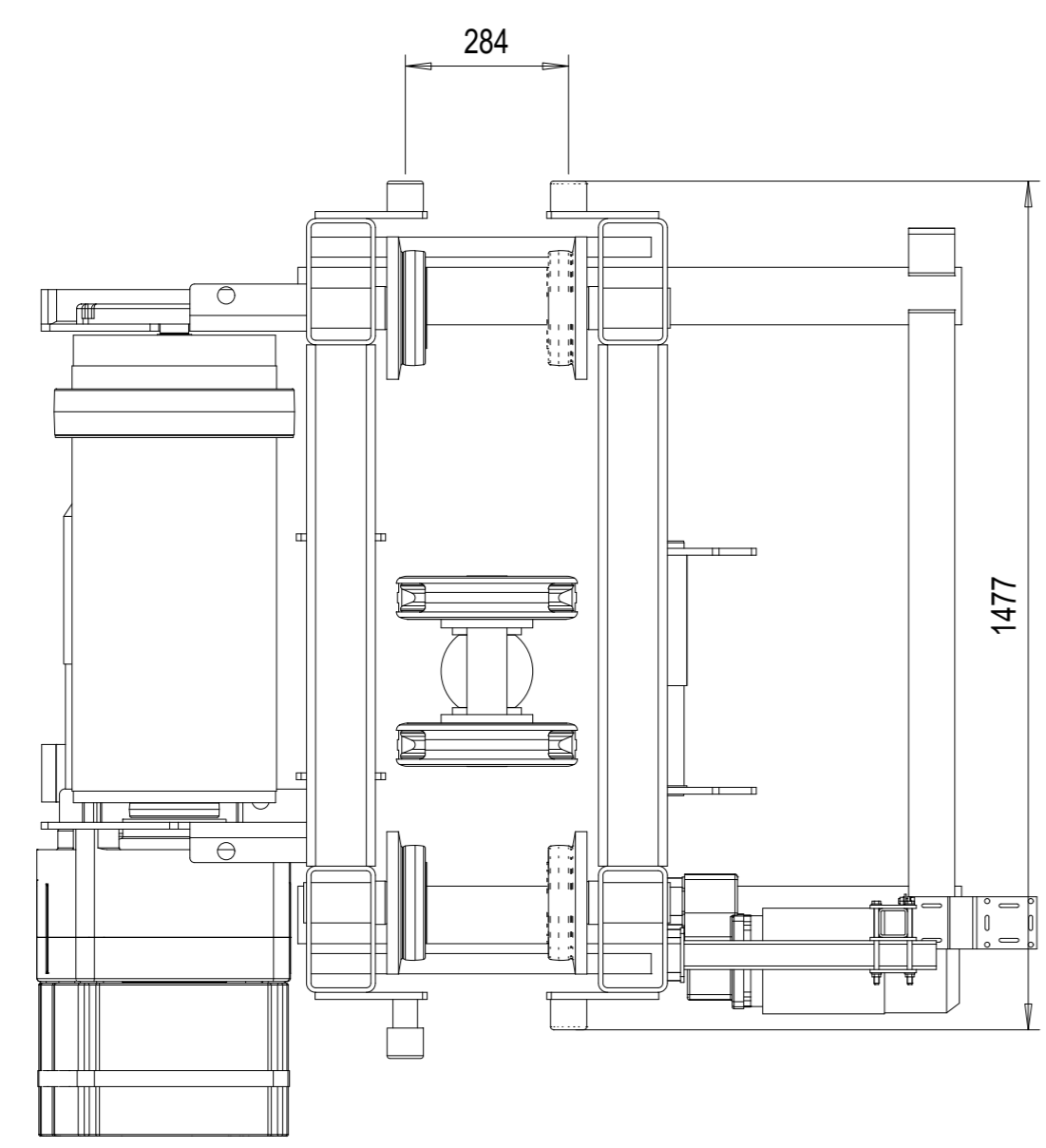
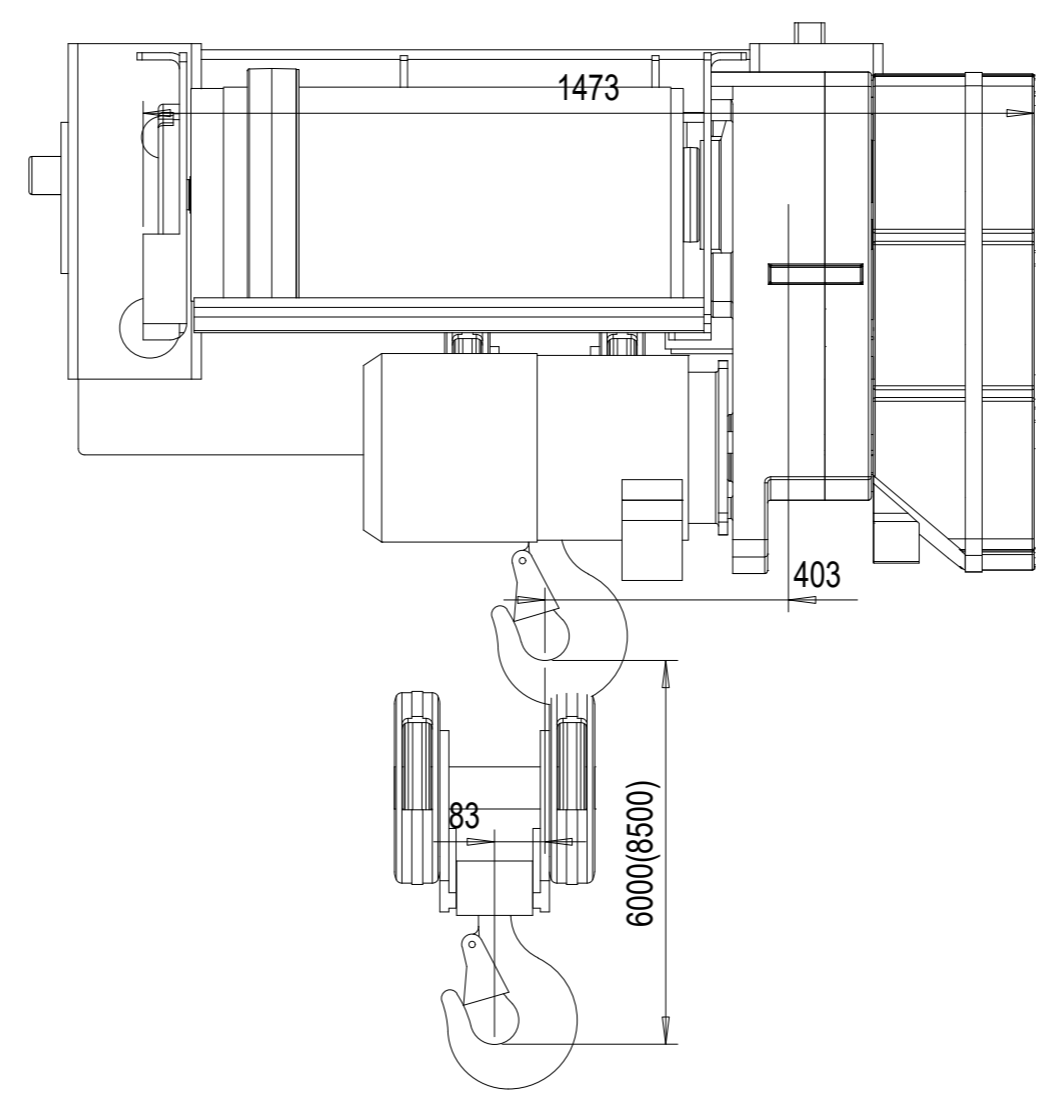
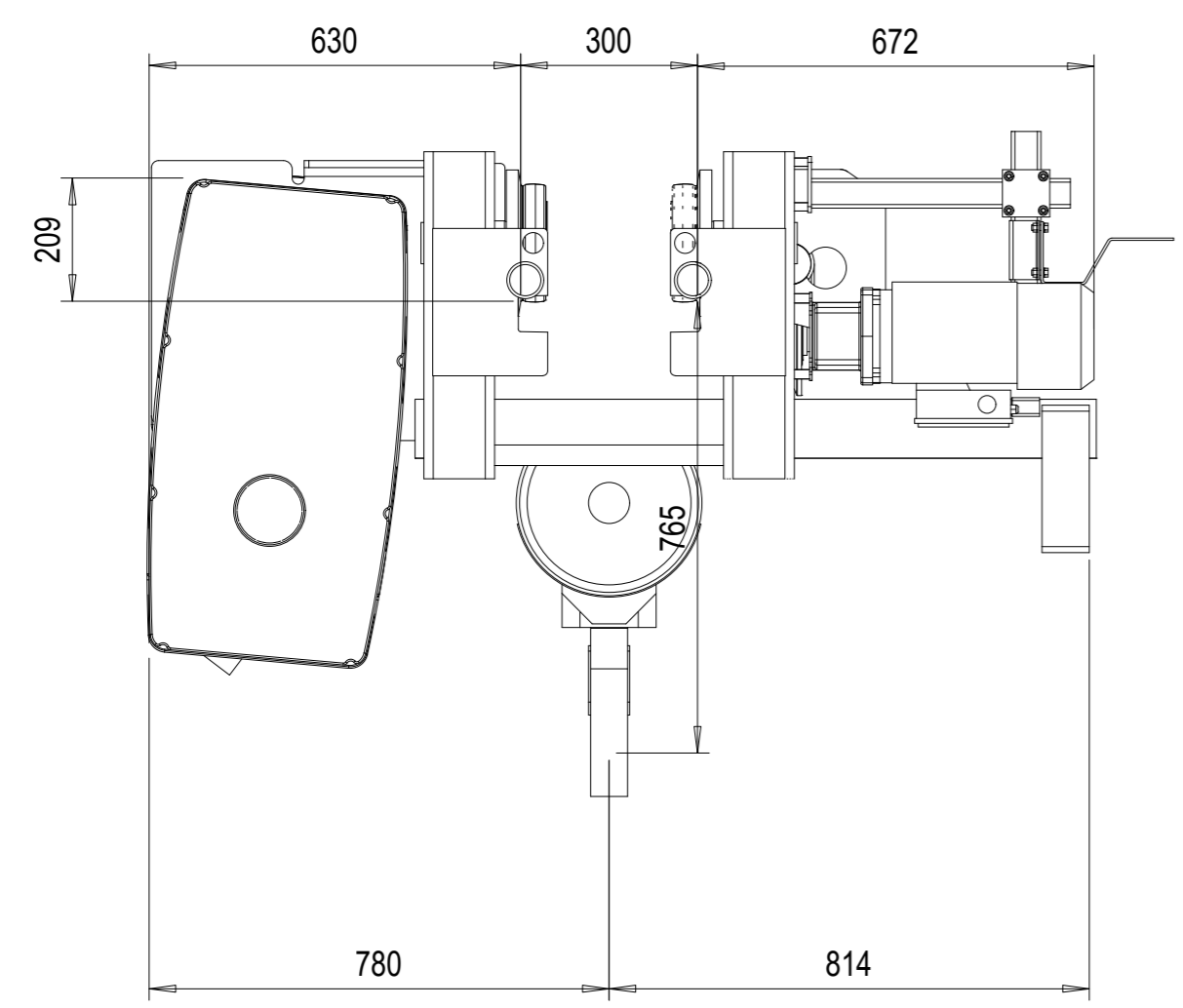

TECHNICAL DATA	
LOAD	: 16000 kg
LIFTING HEIGHT	: 6 m
HOISTING SPEED	: 3,1/0,52 m/min 2-speed
TRAVERSING SPEED	: 20/5 m/min 2-speed pole change
WEIGHT OF HOIST	: 1393 kg
HOIST GROUP	: 3,0 + 3,0 m (D_lin4) / ISO M4
MAIN / CONTROL VOLTAGE	: 380 / 48 V; 50 Hz

Approved:	_____	Place	_____	Date	_____	Company (Company stamp)	_____
Customer	_____						
<b>STAHL</b> CraneSystems	Free size tolerance	Quotation No.				Version	DAS
	Material	Order No.				NSL	
	SHS16t x 4.5m Hol:6m					TCHAR	
Reproduction and transmission to third parties is not permitted We reserve all rights under copyright for this drawing					Scale		
					1:12.5		
Company:		Datum		Name		Copy to	
STEPHAN CraneSystems GmbH		29.05.2019		DMA/XRS		16-4.5-6-O	
Issue	N/a	Released	Replaced by				

Note! Additional options can affect weights and dimensions of some components.

This document is the absolute property of STEPHAN CraneSystems GmbH. This document must not be copied without the written permission of STEPHAN CraneSystems GmbH or its parent company STAHL CraneSystems GmbH. The contents thereof must not be disclosed to a third party nor be used for any unauthorized purpose. Contravention will be prosecuted.

16-4.5-6-O

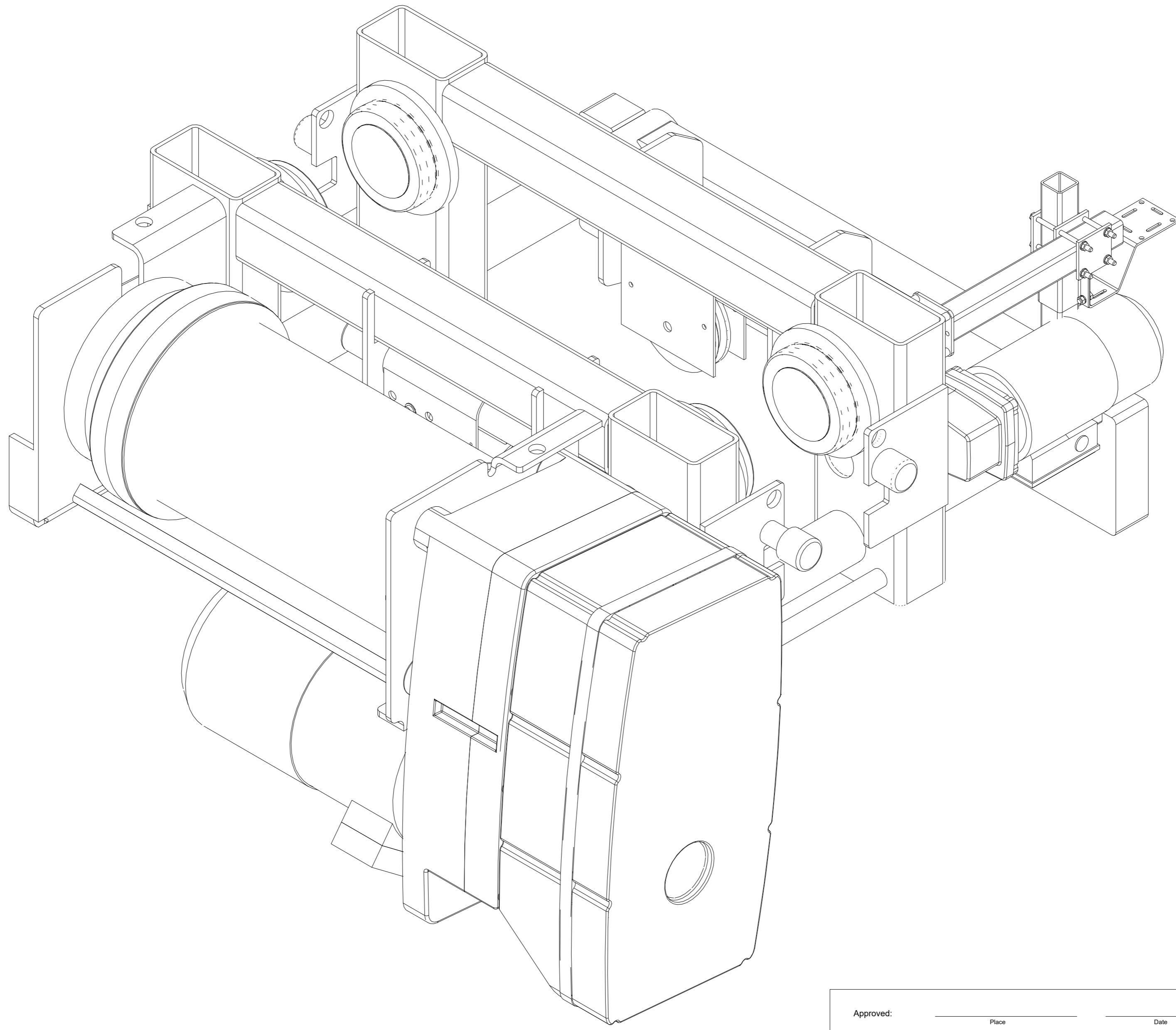

REV	CHANGE DESCRIPTION	ECN	DATE	REVISED BY	APPROVED BY
-----	--------------------	-----	------	------------	-------------

This document is the absolute property of STEPHAN CraneSystems GmbH. This document must not be copied without the written permission of STEPHAN CraneSystems GmbH or its parent company STAHL CraneSystems GmbH. This document is not to be used for any unauthorized purpose. Contravention will be prosecuted.

Approved: _____		Place _____		Date _____		Company (Company stamp) _____	
Customer _____		Free size tolerance _____		Quotation No. _____		Version DAS	
		Material _____		Order No. _____		NSL	
				Reproduction and transmission to third parties is not permitted		TCHAR	
				We reserve all rights under copyright for this drawing		Scale	
				SHS16t x 4.5m Hol:6m		1:2.5	
Company: STEPHAN CraneSystems GmbH		Datum _____		Name _____		Copy to _____	
		Drawn by 29.05.2019 DMA/XRS					
		Checked by _____					
Issue _____		N/a		Released _____		Replaced by _____	

Note! Additional options can affect weights and dimensions of some components.