

16-22.5-18-O

REV	CHANGE DESCRIPTION	ECN	DATE	REVISED BY	APPROVED BY
-----	--------------------	-----	------	------------	-------------

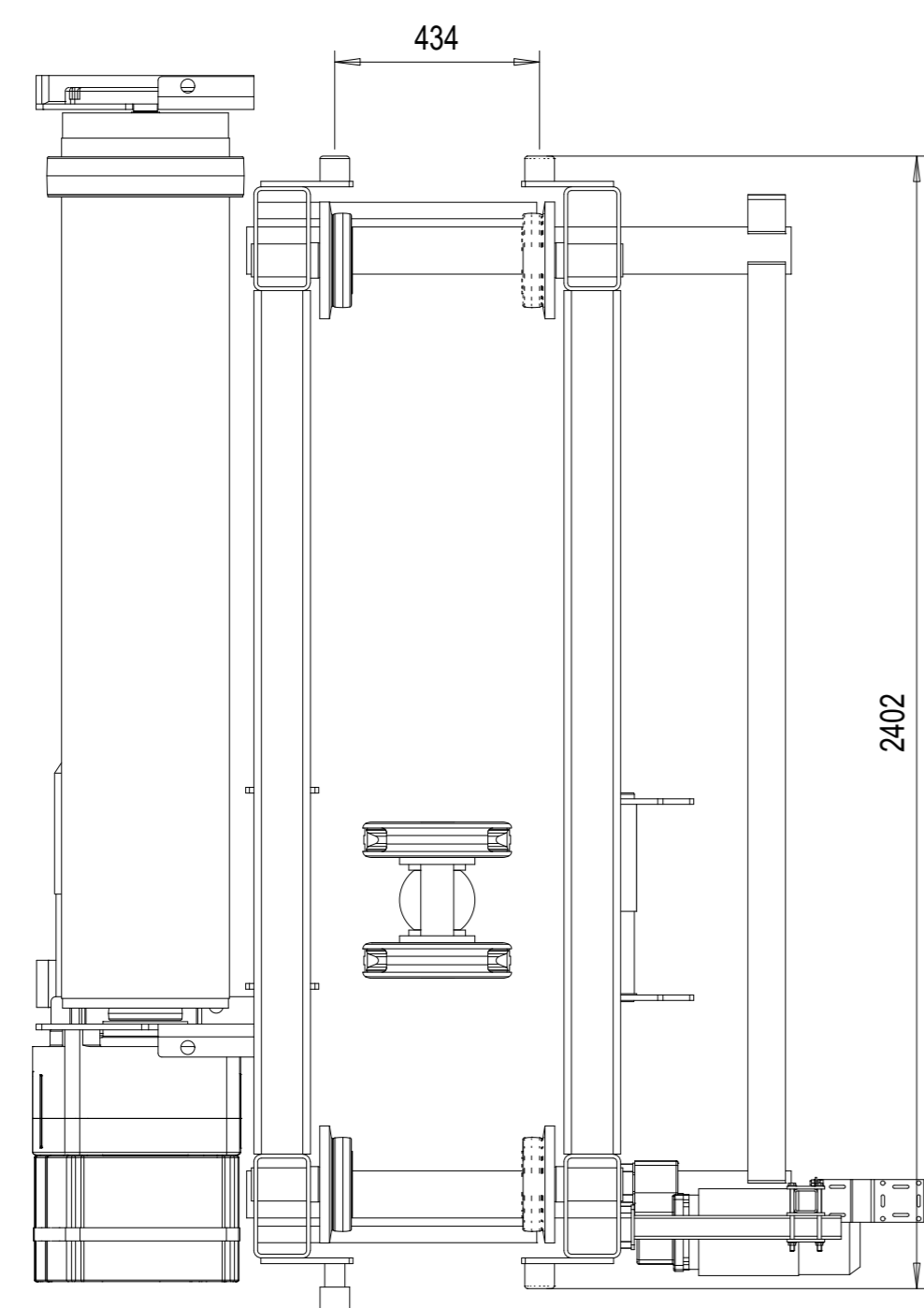
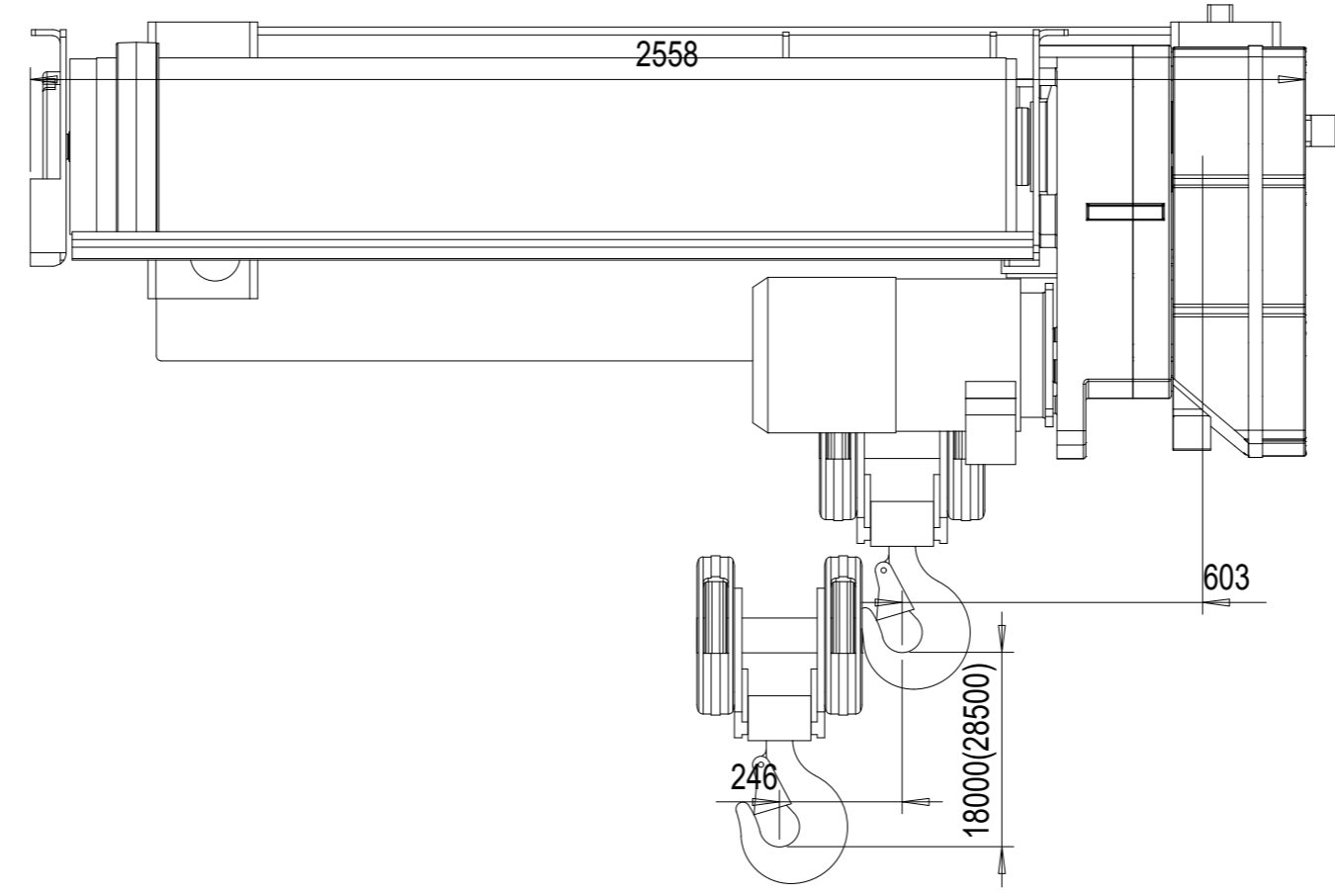
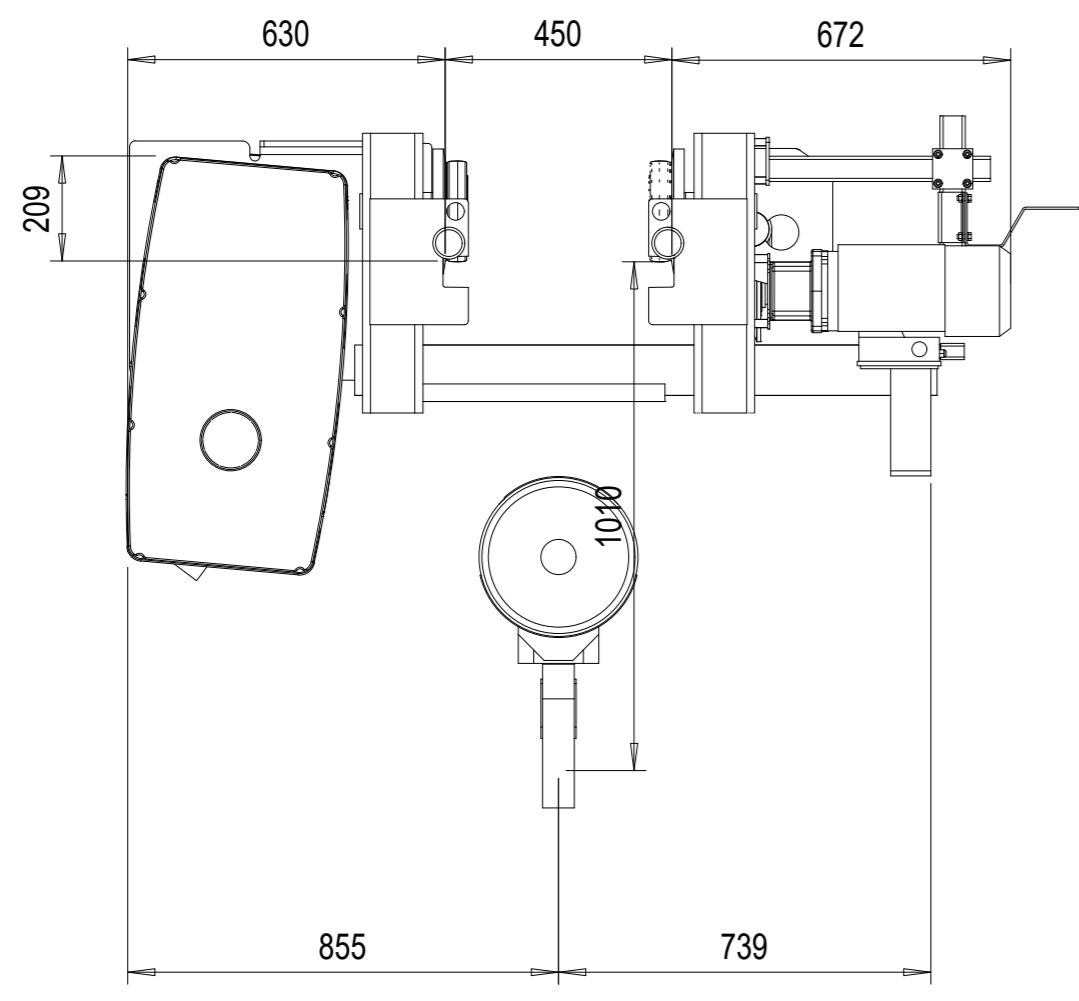

TECHNICAL DATA

LOAD	: 16000 kg
LIFTING HEIGHT	: 18 m
HOISTING SPEED	: 3,1/0,52 m/min 2-speed
TRAVERSING SPEED	: 20/5 m/min 2-speed pole change
WEIGHT OF HOIST	: 1803 kg
HOIST GROUP	: 4,0 + 4,0 m (D_lin4) / ISO M4
MAIN / CONTROL VOLTAGE	: 380 / 48 V; 50 Hz

Approved: _____ Place _____ Date _____ Company (Company stamp) _____
 Customer _____

	Free size tolerance	Quotation No.	Version DAS
	Material	Order No.	NSL
	Reproduction and transmission to third parties is not permitted We reserve all rights under copyright for this drawing		TCHAR
SHS16t x 22.5m Hol:18m		Scale	1:15.0
Company: STEPHAN CraneSystems GmbH		Copy to	
Issue	N/a	16-22.5-18-O	
Drawn by	29.05.2019 DMA/XRS	Replaced by	
Checked by			
Released			

Note! Additional options can affect weights and dimensions of some components.

This document is the absolute property of STEPHAN CraneSystems GmbH. This document must not be copied without the written permission of STEPHAN CraneSystems GmbH or its parent company STAHL CraneSystems GmbH. The contents thereof must not be disclosed to a third party nor be used for any unauthorized purpose. Contravention will be prosecuted.

16-22.5-18-O

This document is the absolute property of STEPHAN CraneSystems GmbH. This document must not be copied without the written permission of STEPHAN CraneSystems GmbH or its parent company STAHL CraneSystems GmbH. This document is intended for use by a third party for the purpose of any unauthorized purpose. Contravention will be prosecuted.

REV	CHANGE DESCRIPTION	ECN	DATE	REVISED BY	APPROVED BY
-----	--------------------	-----	------	------------	-------------

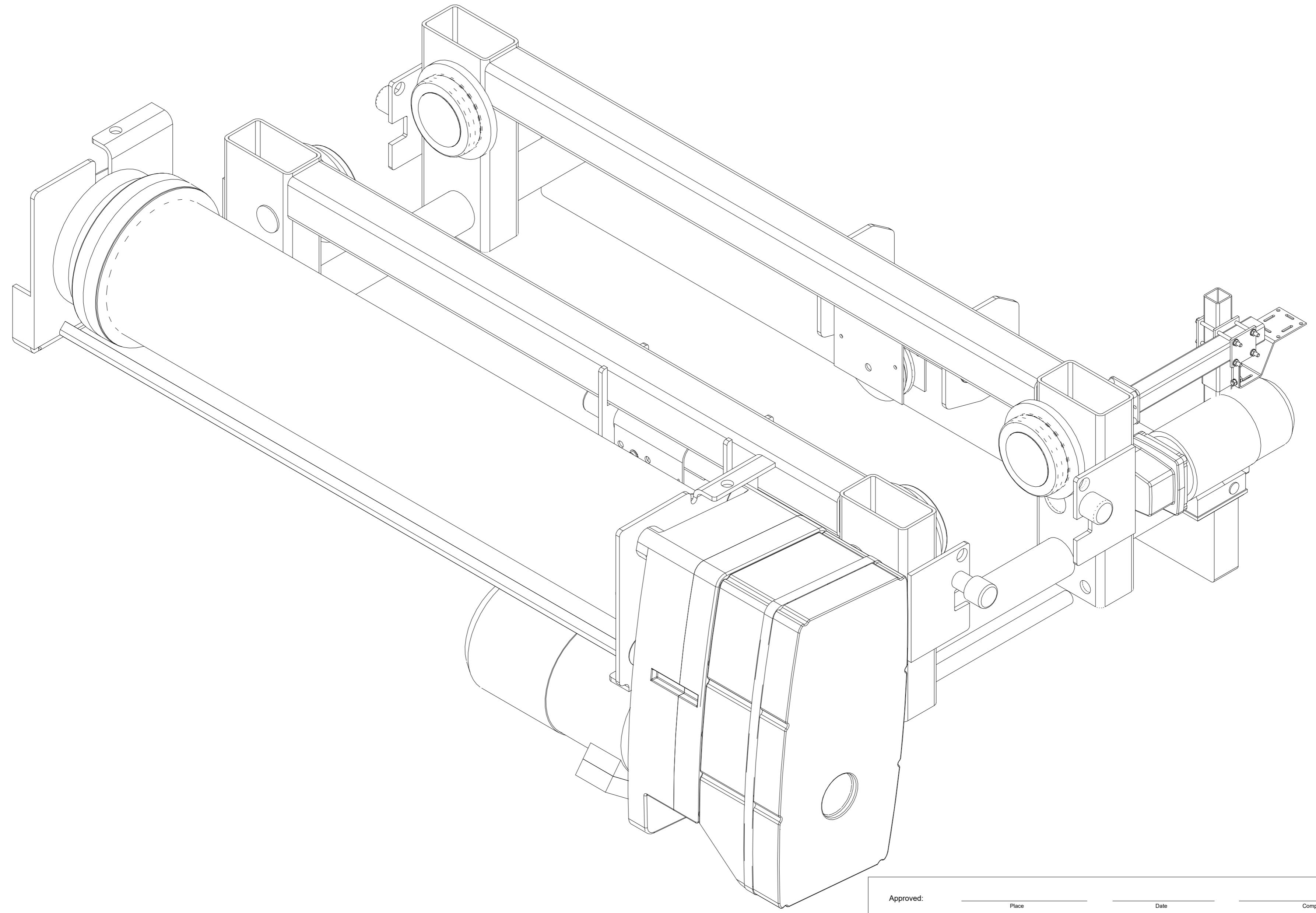

Approved: _____		Place _____		Date _____		Company (Company stamp) _____	
Customer _____		Free size tolerance _____		Quotation No. _____		Version DAS	
		Material _____		Order No. _____		NSL	
				Reproduction and transmission to third parties is not permitted		TCHAR	
Company: STEPHAN CraneSystems GmbH		Drawn by 29.05.2019 DMA/XRS Checked by _____ Released by _____		SHS16t x 22.5m Hol:18m		Scale 1:2.5	
				16-22.5-18-O		Copy to _____	
Issue _____	N/a	Replaced by _____		_____		_____	

Note! Additional options can affect weights and dimensions of some components.