

16-10.5-12-ex-OEx

REV	CHANGE DESCRIPTION	ECN	DATE	REVISED BY	APPROVED BY
-----	--------------------	-----	------	------------	-------------

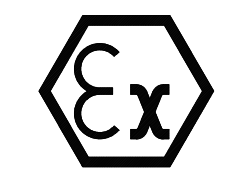
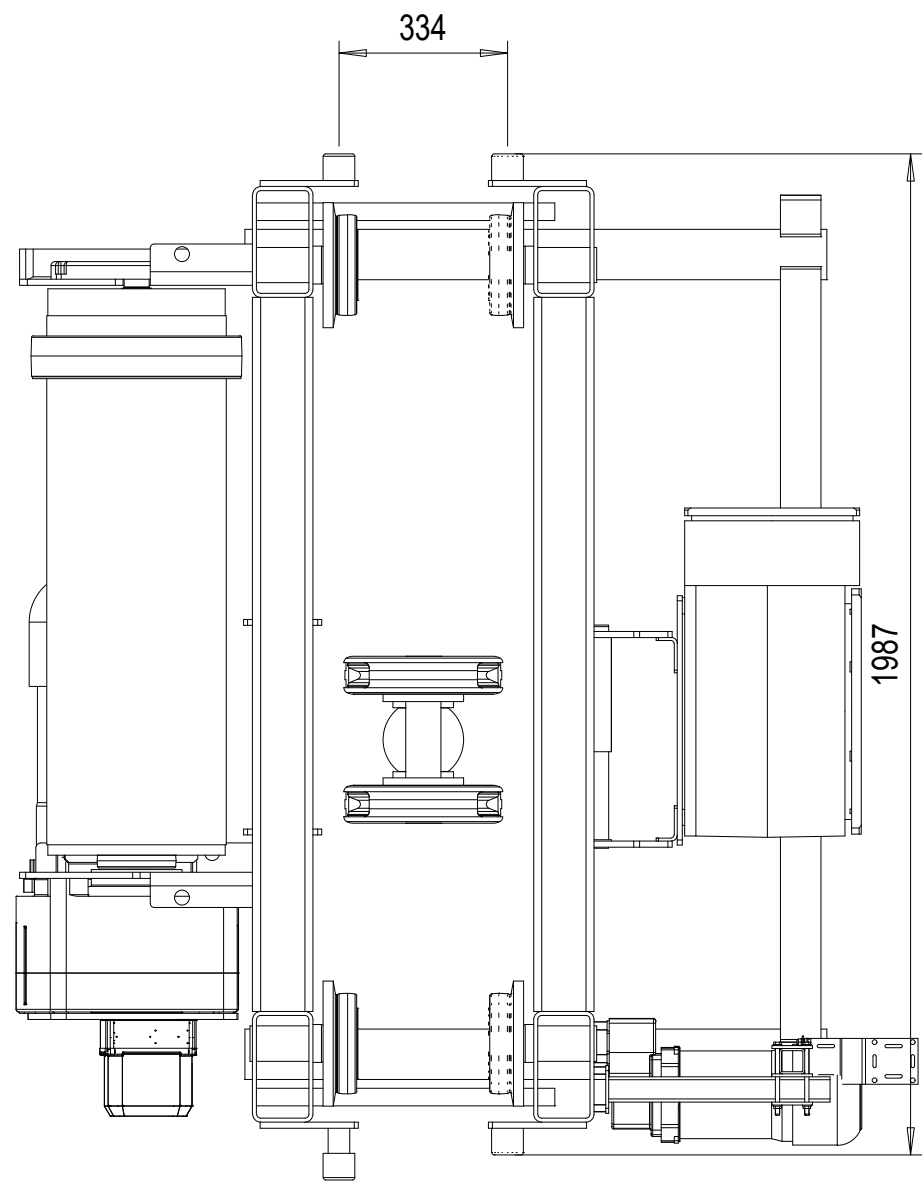
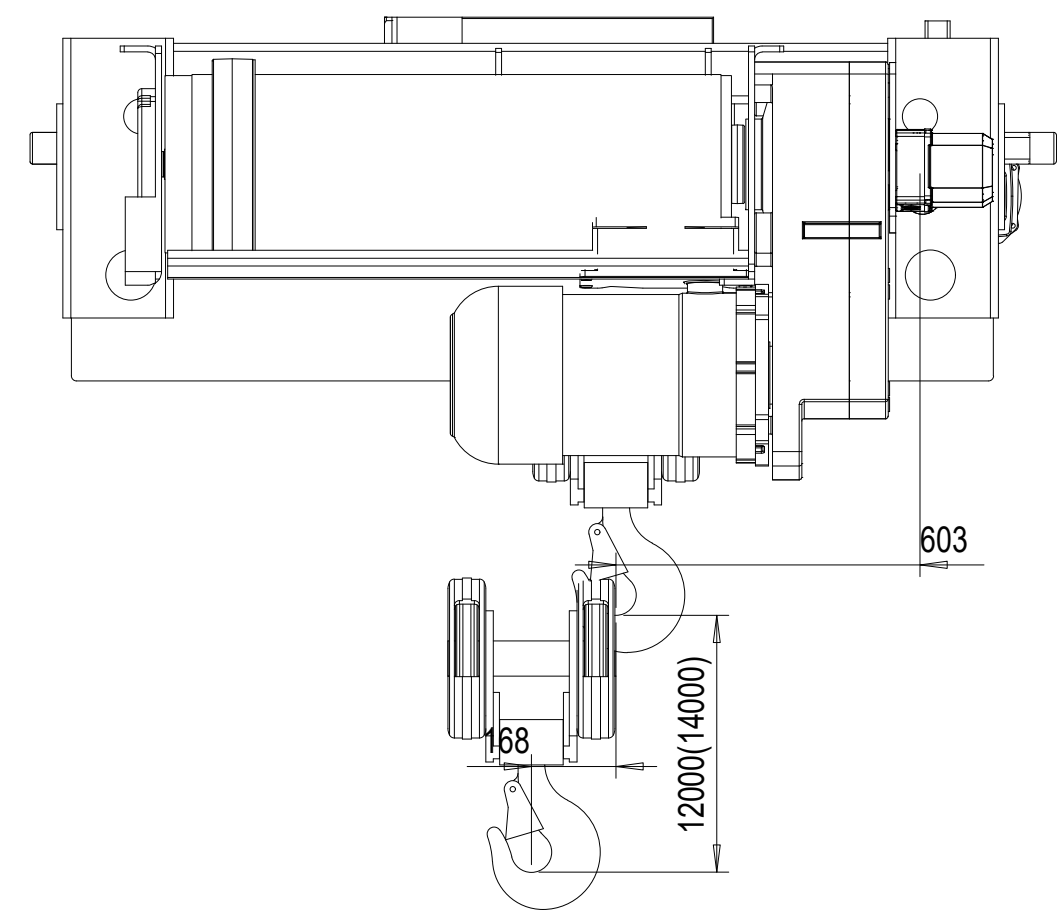
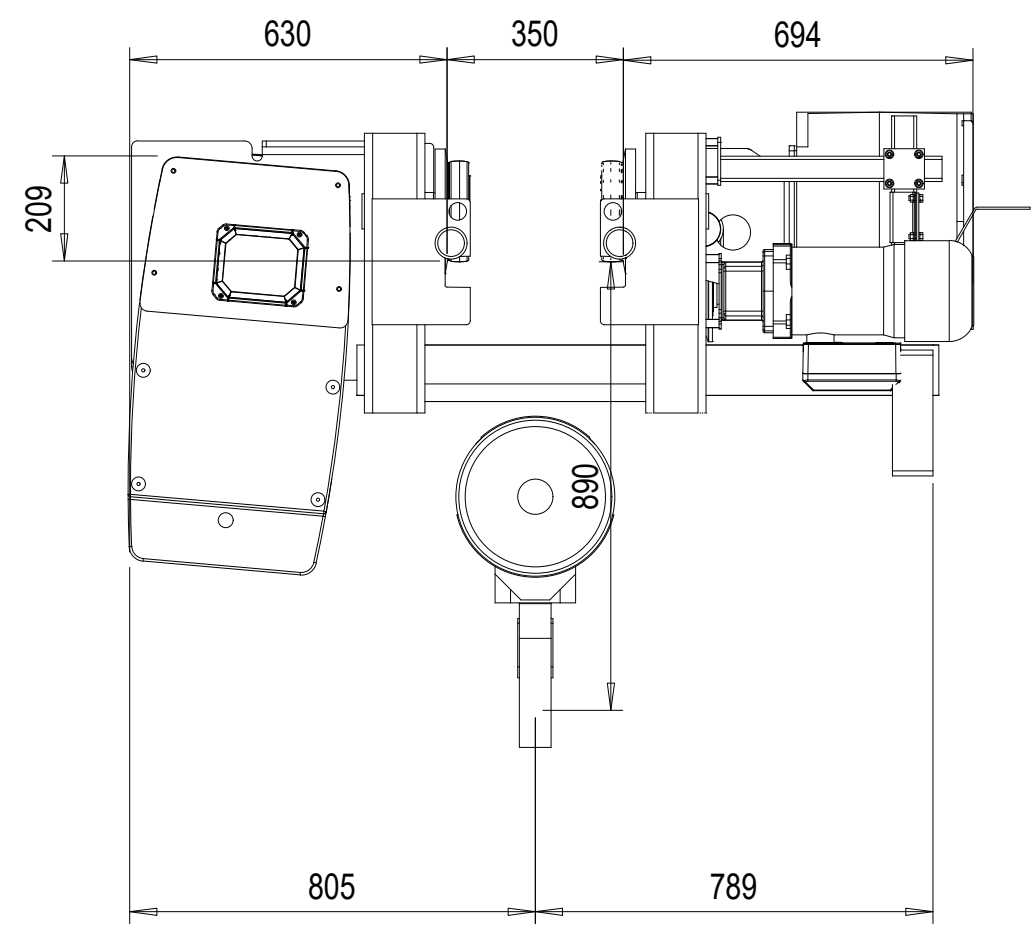

Marking : Ex II 2G Ex de IIB T4 Gb/Ex II 2G ck IIB T4
 Ambient temperature : -10°...40° C

TECHNICAL DATA	
LOAD	: 16000 kg
LIFTING HEIGHT	: 12 m
HOISTING SPEED	: 3,8/0,63 m/min 2-speed
TRAVERSING SPEED	: 20/5 m/min 2-speed pole change
WEIGHT OF HOIST	: 1710 kg
HOIST GROUP	: 4,0 + 4,0 m (D_lin4) / ISO M4
MAIN / CONTROL VOLTAGE	: 380 / 48 V; 50 Hz

Approved: _____ Place _____ Date _____ Company (Company stamp) _____
 Customer _____

	Free size tolerance	Quotation No.	Version DAS
	Material	Order No.	NSL
	Reproduction and transmission to third parties is not permitted We reserve all rights under copyright for this drawing		TCHAR
	SHS EX 16t x 10.5m Hol:12m		Scale
Company: STEPHAN CraneSystems GmbH		16-10.5-12-ex-OEx	1:15.0
Issue	N/a	Replaced by	Copy to

Note! Additional options can affect weights and dimensions of some components.

This document is the absolute property of STEPHAN CraneSystems GmbH. This document must not be copied without the written permission of STEPHAN CraneSystems GmbH or its parent company STAH CraneSystems GmbH. The contents thereof must not be disclosed to a third party nor be used for any unauthorized purpose. Contravention will be prosecuted.

16-10.5-12-ex-OEx

REV	CHANGE DESCRIPTION	ECN	DATE	REVISED BY	APPROVED BY
-----	--------------------	-----	------	------------	-------------

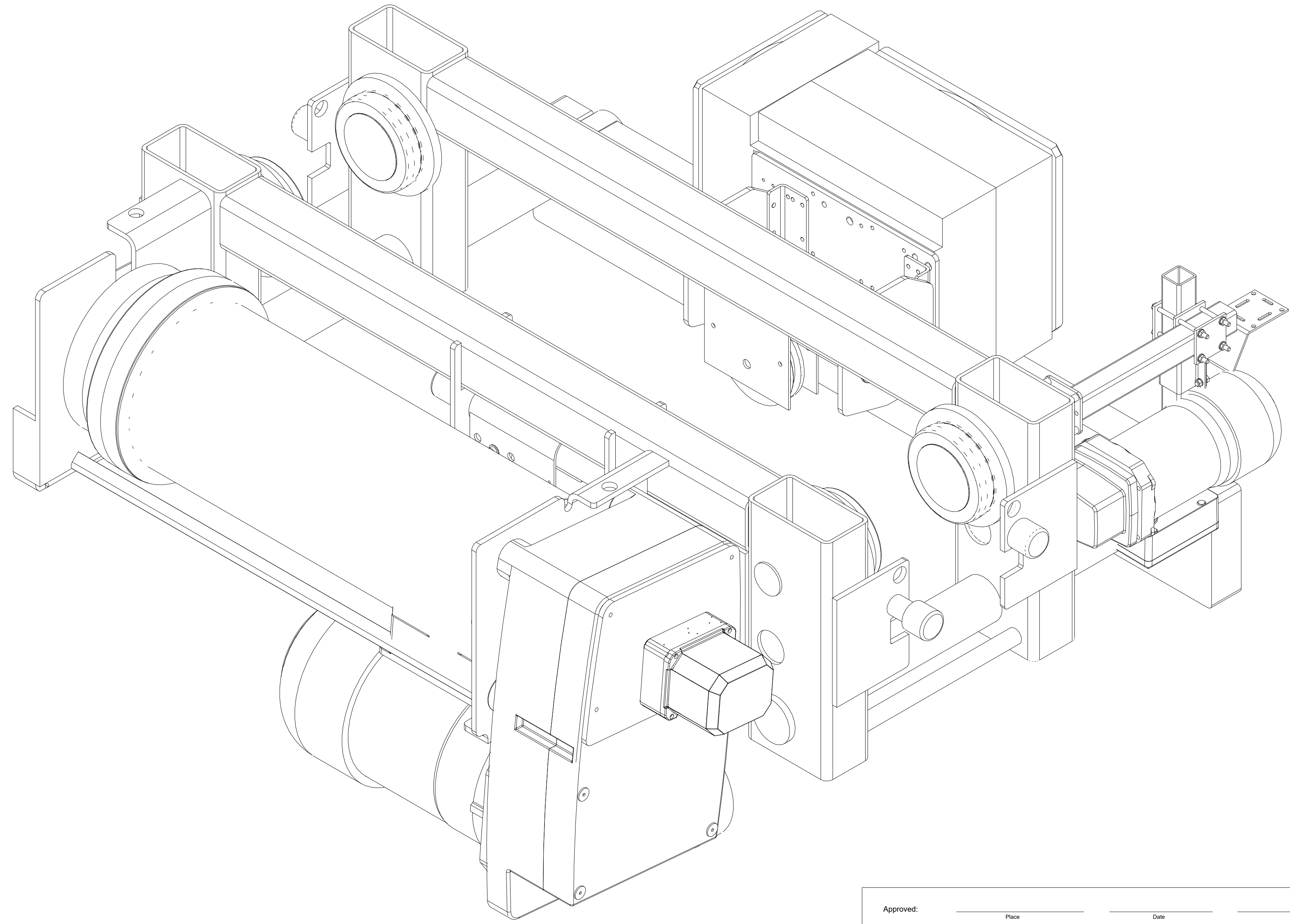

This document is the absolute property of STEPHAN CraneSystems GmbH. This document must not be copied without the written permission of STEPHAN CraneSystems GmbH or its parent company STAHL CraneSystems GmbH. This document is intended for use by a third party for any unauthorized purpose. Contravention will be prosecuted.

Approved: _____		Place _____		Date _____		Company (Company stamp) _____	
Customer _____		Free size tolerance _____		Quotation No. _____		Version DAS	
		Material _____		Order No. _____		NSL	
				Reproduction and transmission to third parties is not permitted We reserve all rights under copyright for this drawing SHS EX 16t x 10.5m Hol:12m		TCHAR	
Company: STEPHAN CraneSystems GmbH		Datum 28.05.2019		Name DMA/XRS		Scale 1:2.5	
Issue _____		N/a		Released _____		Copy to _____	
				16-10.5-12-ex-OEx		Replaced by _____	

Note! Additional options can affect weights and dimensions of some components.