

3.2-19.5-18-ex-OEx

REV	CHANGE DESCRIPTION	ECN	DATE	REVISED BY	APPROVED BY
-----	--------------------	-----	------	------------	-------------

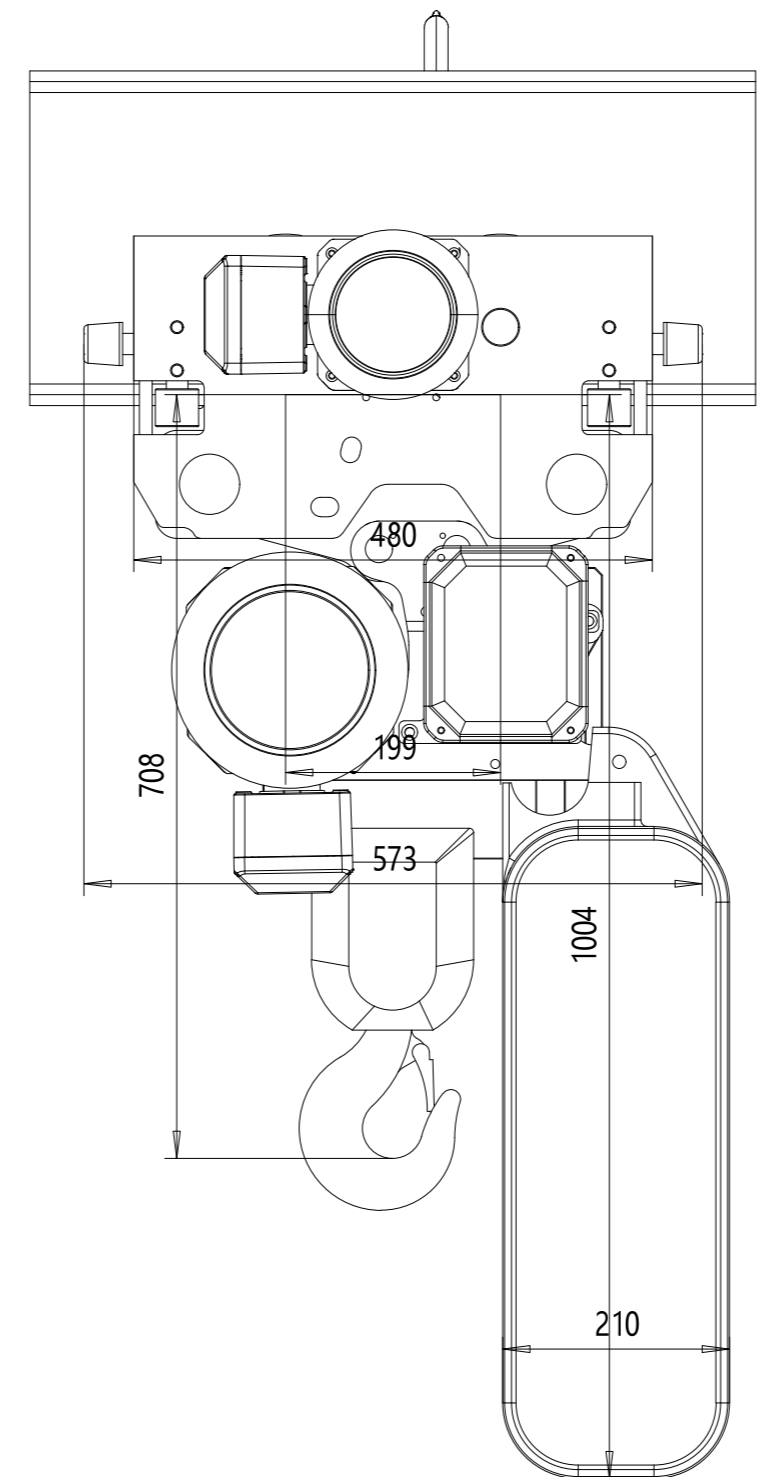
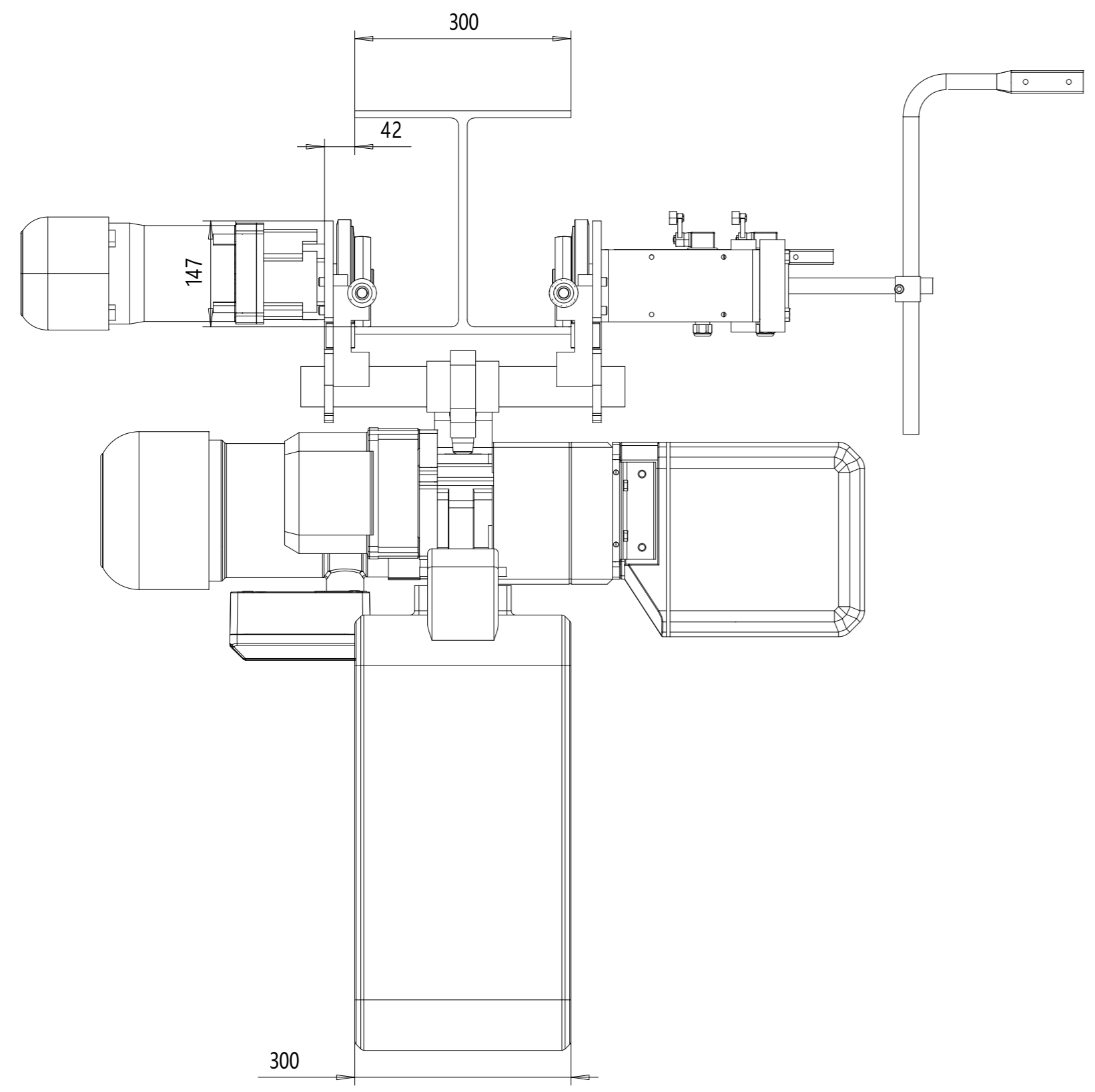

Marking : Ex II 2G Ex de IIB T4 Gb/Ex II 2G ck IIB T4
 Ambient temperature : -10° ...40° C

TECHNICAL DATA	
LOAD	: 3200 kg
LIFTING HEIGHT	: 18 m
HOISTING SPEED	: 2/0,33 m/min 2-speed
TRAVERSING SPEED	: 20/5 m/min 2-speed pole change
WEIGHT OF HOIST	: 373 kg
HOIST GROUP	: 4,0 + 4,0 m (D_lin4) / ISO M5
MAIN / CONTROL VOLTAGE	: 380 / 48 V; 50 Hz

Approved: _____ Place _____ Date _____ Company (Company stamp)
 Customer _____

	Free size tolerance	Quotation No.	Version DAS
	Material	Order No.	NSL
	Reproduction and transmission to third parties is not permitted We reserve all rights under copyright for this drawing		TCHAR
	STS EX 3.2t x 19.5m Hol:18m		Scale
Company: STEPHAN CraneSystems GmbH		3.2-19.5-18-ex-OEx	Copy to
Drawn by: 08.07.2019 DMA/XRS Checked by: Released:	Datum: _____ Name: _____	Replaced by: _____	

Note! Additional options can affect weights and dimensions of some components.

This document is the absolute property of STEPHAN CraneSystems GmbH. This document must not be copied
 without the written permission of STEPHAN CraneSystems GmbH. The copyright for this drawing is reserved
 to STEPHAN CraneSystems GmbH. The contents thereof must not be disclosed to a third party nor be used for any unauthorized
 purpose. Contravention will be prosecuted.

3.2-19.5-18-ex-OEx

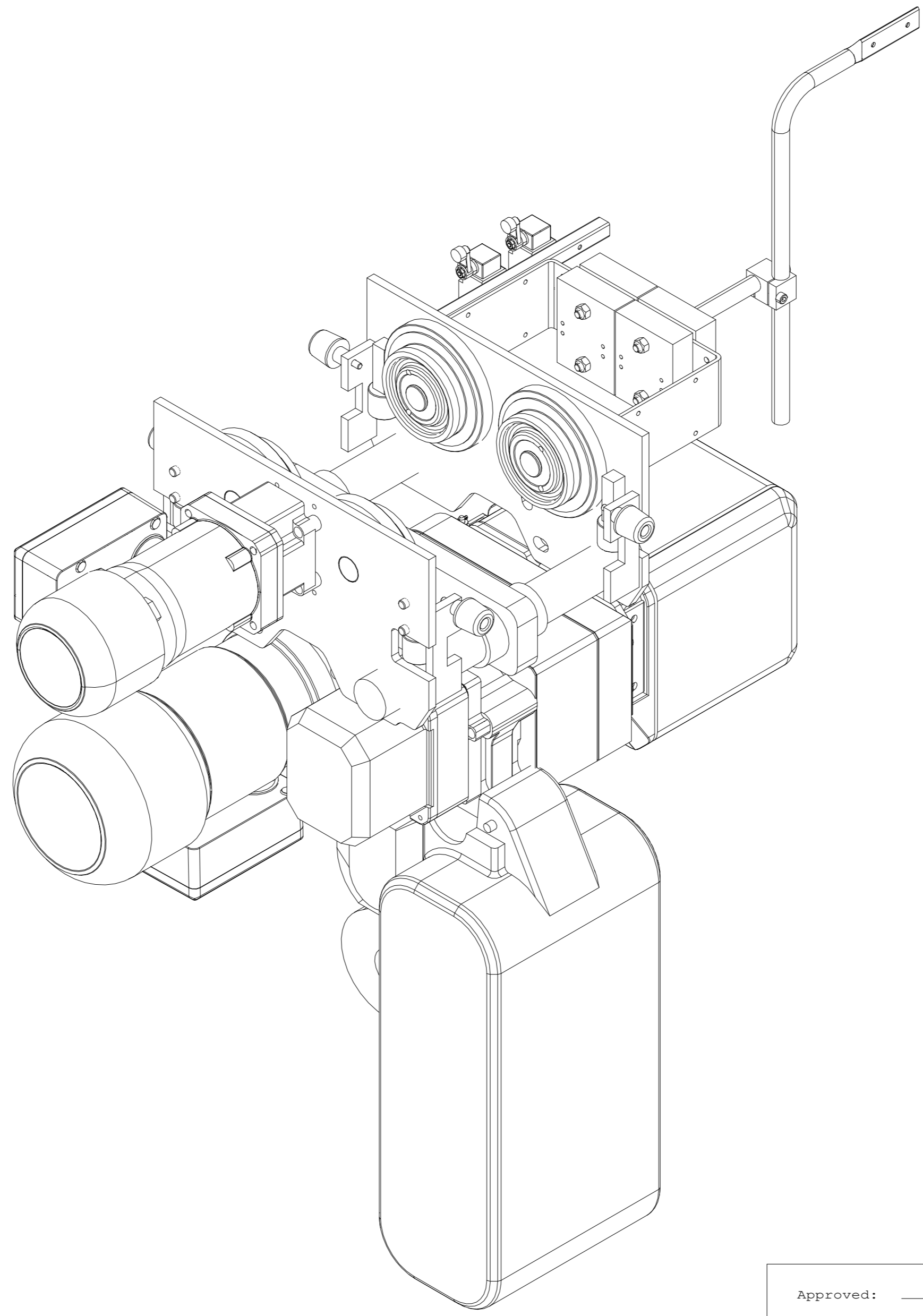

REV	CHANGE DESCRIPTION	ECN	DATE	REVISED BY	APPROVED BY
-----	--------------------	-----	------	------------	-------------

This document is the absolute property of STEPHAN CraneSystems GmbH. This document must not be copied without the written permission of STEPHAN CraneSystems GmbH or its parent company STAHL CraneSystems GmbH. The contents thereof must be disclosed to a third party nor be used for any unauthorized purpose. Concomitant will be prosecuted.

Approved: _____		Place _____		Date _____		Company (Company stamp) _____	
Customer _____		Free size tolerance _____		Quotation No. _____		Version DAS	
		Material _____		Order No. _____		NSL	
				Reproduction and transmission to third parties is not permitted We reserve all rights under copyright for this drawing		TCHAR	
Company: STEPHAN CraneSystems GmbH		Drawn by: 08.07.2019 DMA/XRS Checked by: _____ Released: _____		STS EX 3.2t x 19.5m Hol:18m		Scale	
				3.2-19.5-18-ex-OEx		1:2.5	
				Replaced by _____		Copy to _____	

Note! Additional options can affect weights and dimensions of some components.