

REV	CHANGE DESCRIPTION	ECN	DATE	REVISED BY	APPROVED BY
-----	--------------------	-----	------	------------	-------------

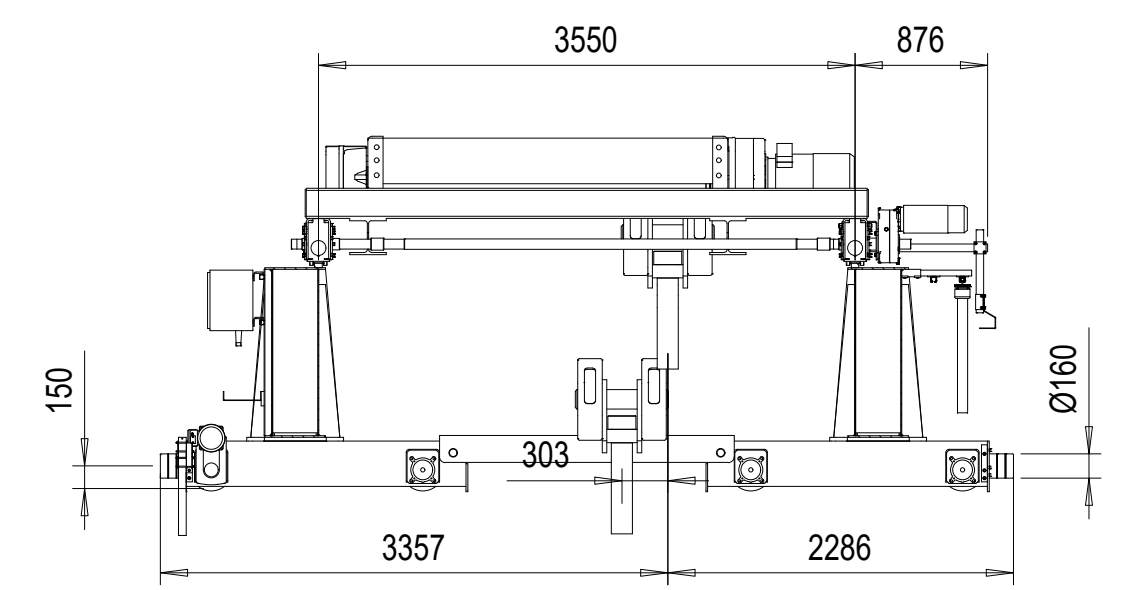
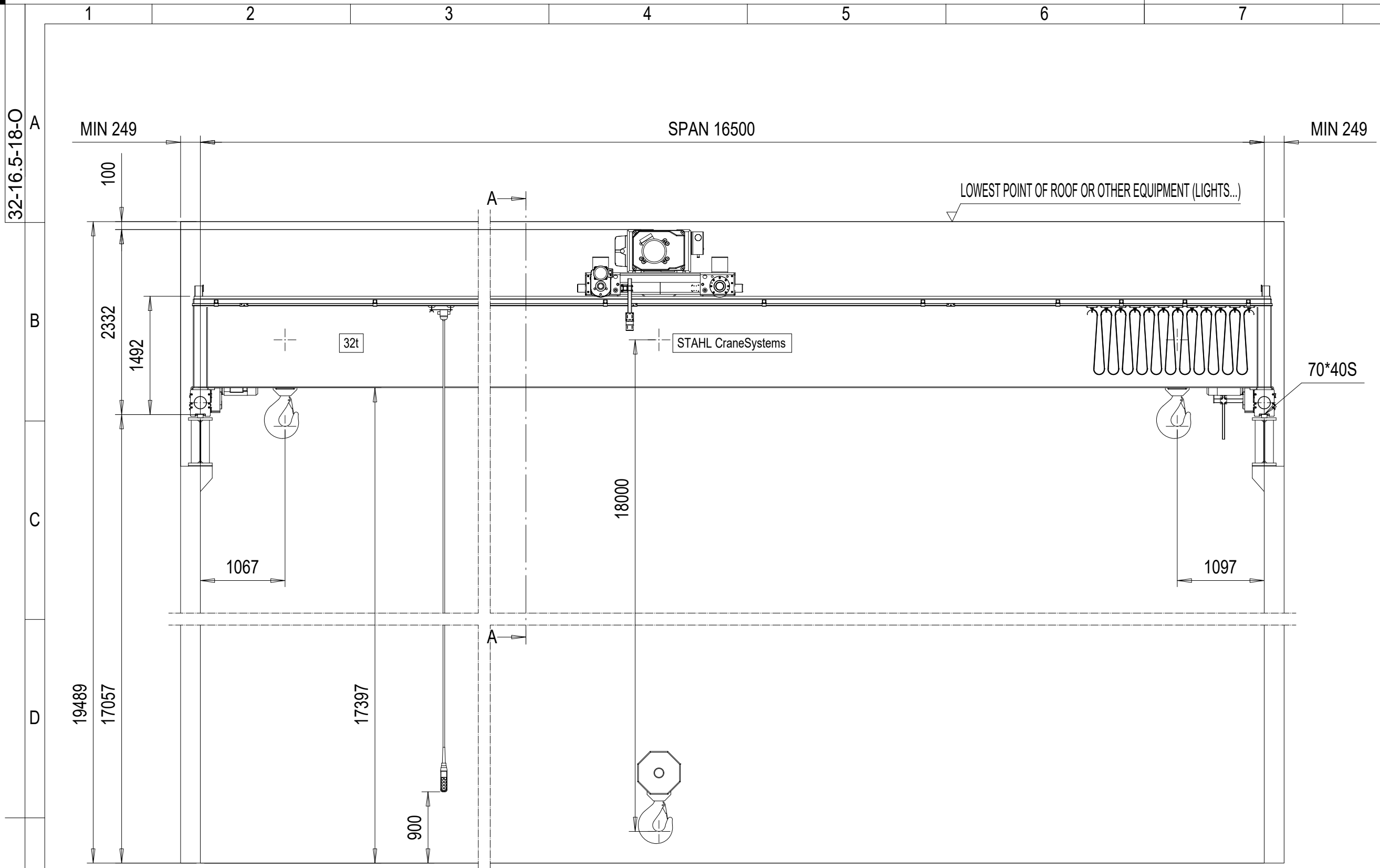

VIEW A-A

**TECHNICAL DATA**

<b>CRANE</b>	
LOAD	: 32000 kg
SPAN	: 16.5 m
LIFTING HEIGHT	: 18 m
TRAVELLING SPEED	: 40/10 m/min 2-speed pole change
WEIGHT OF BRIDGE	: 9220 kg
TOTAL WEIGHT	: 12930 kg
CRANE CLASSIFICATION	: U4/Q2, EN13001-1
CRANE DRIVE GROUP	: 25 m (D_lin6) / M5
LENGTH OF RUNWAY	: 50 m
<b>HOIST</b>	
HOISTING SPEED	: 4/0.67 m/min 2-speed
TRAVERSING SPEED	: 20/5 m/min 2-speed pole change
WEIGHT OF TROLLEY	: 3710 kg
HOIST GROUP	: 3,0 + 3,0 m (D_lin4) / ISO M4
<b>ELECTRICAL EQUIPMENT</b>	
MAIN/CONTROL VOLTAGE	: 380 / 48 V; 50 Hz
SUPPLY POWER	: 30 kW

**TOLERANCES**

CRANE	:
RUNWAY	:

**USE OF CRANE**

: Indoor Use crane -10° ...40° C  
 CUSTOMER ORGANIZES SAFE PLATFORM FOR CRANE SERVICE

Project sketch - for information only  
 Subject to changes without prior notice  
 Projektskizze - Änderungen vorbehalten

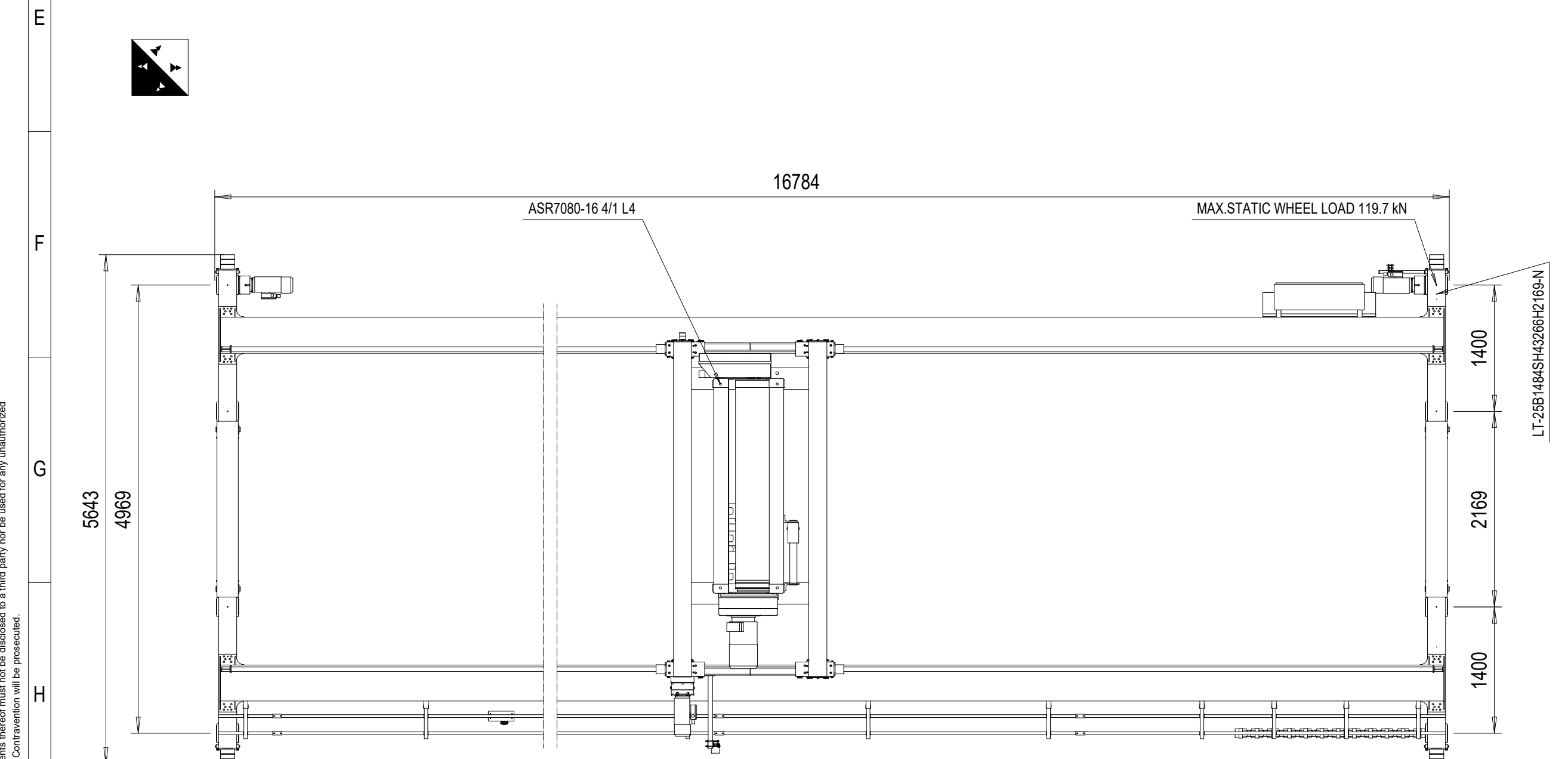

Note! Additional options can affect weights and dimensions of some components.

Approved:	Place	Date	Company (Company stamp)
Customer			
	Free size tolerance	Quotation No.	Version DAS
	Material	Order No.	NSL
	Reproduction and transmission to third parties is not permitted We reserve all rights under copyright for this drawing <b>SHD32t x 16.5m Ho:18m</b>		TCHAR
Company: STEPHAN CraneSystems GmbH		Datum	Name
Down by: 11.04.2019 DMA/XRS		Scale	
Checked by:		1:50	
Released		Copy to	
Issue	N/a	Replaced by	

This document is the absolute property of STEPHAN CraneSystems GmbH. This document must not be copied without the written permission of STEPHAN CraneSystems GmbH or its parent company STAHl CraneSystems GmbH. The contents thereof must not be disclosed to a third party nor be used for any unauthorized purpose. Contravention will be prosecuted.

REV	CHANGE DESCRIPTION	ECN	DATE	REVISED BY	APPROVED BY
-----	--------------------	-----	------	------------	-------------

32-16.5-18-O-I

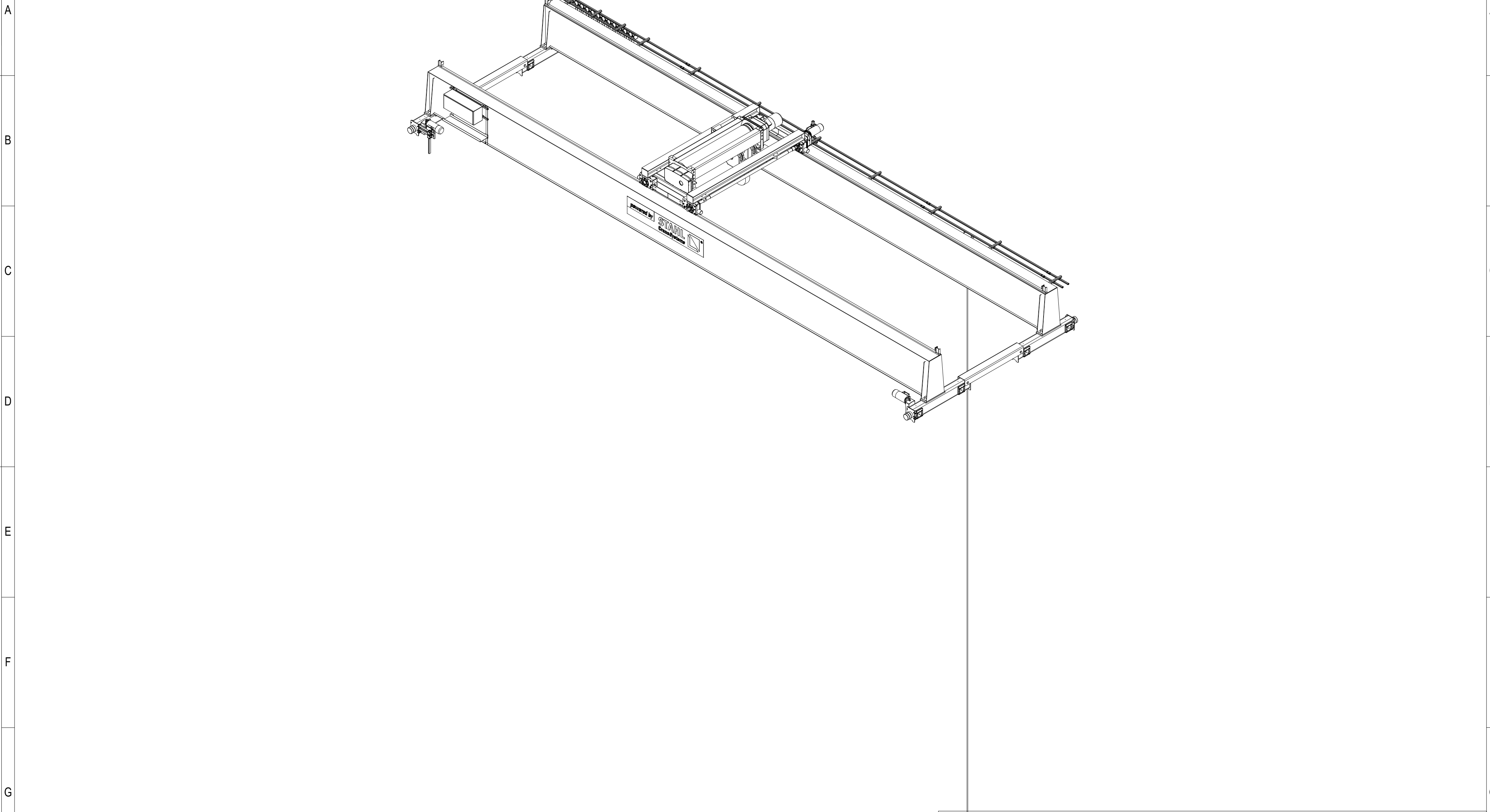

Approved: _____		Place _____		Date _____		Company (Company stamp) _____		
Customer								
	Free size tolerance		Quotation No.			Version DAS		
	Material		Order No.			NSL		
	Reproduction and transmission to third parties is not permitted						TCHAR	
	We reserve all rights under copyright for this drawing						Scale	
SHD32t x 16.5m Hol:18m						1:2.5		
Company:		Datum		Name		Copy to		
STEPHAN CraneSystems GmbH		11.04.2019		DMA/XRS		32-16.5-18-O-I		
Issue		N/a		Released		Replaced by		

This document is the absolute property of STEPHAN CraneSystems GmbH. This document must not be copied without the written permission of STEPHAN CraneSystems GmbH or its parent company STAHL CraneSystems GmbH. This document is not to be used for any unauthorized purpose. Contravention will be prosecuted.